

Commission Meeting Agenda



Mayor

Samuel D. Cobb

City Commission

R. Finn Smith – District 1
Christopher R. Mills – District 2
Larron B. Fields – District 3
Joseph D. Calderón – District 4
Dwayne Penick – District 5
Don R. Gerth – District 6

City Manager

Manny Gomez

March 20, 2023



Hobbs City Commission

Regular Meeting

City Hall, City Commission Chamber

200 E. Broadway, 1st Floor Annex, Hobbs, New Mexico

Monday, March 20, 2023 - 6:00 p.m.

Sam D. Cobb, Mayor

R. Finn Smith
Commissioner – District 1

Christopher R. Mills
Commissioner – District 2

Larron B. Fields
Commissioner – District 3

Joseph D. Calderón
Commissioner – District 4

Dwayne Penick
Commissioner – District 5

Don R. Gerth
Commissioner – District 6

A G E N D A

City Commission Meetings are
Broadcast Live on KHBX FM 99.3 Radio and
Available via Livestream at www.hobbsnm.org

CALL TO ORDER AND ROLL CALL

INVOCATION AND PLEDGE OF ALLEGIANCE

APPROVAL OF MINUTES

1. Minutes of the March 6, 2023, Regular Commission Meeting (*Jan Fletcher, City Clerk*)

PROCLAMATIONS AND AWARDS OF MERIT

2. Recognition of City Employees - Milestone Service Awards for the Month of March, 2023 (*Manny Gomez, City Manager*)
 - 5 years – Beatriz Hernandez, Parks & Open Spaces Department
 - 5 years – Barry Muniz, CORE
 - 15 years – Shane Cox, Wastewater Treatment Plant
 - 30 years – Roberto Gonzalez, Senior Center
 - 35 years – Tommy Trevino, Building Maintenance

PUBLIC COMMENTS *(Citizens who wish to speak must sign the Public Comment Registration Form located in the Commission Chamber prior to the beginning of the meeting.)*

CONSENT AGENDA *(The consent agenda is approved by a single motion. Any member of the Commission may request an item to be transferred to the regular agenda from the consent agenda without discussion or vote.)*

None

DISCUSSION

3. Presentation of 2022 Annual Report for the Hobbs Fire Department *(Barry Young, Fire Chief, and Mark Doporto, Deputy Fire Chief)*

ACTION ITEMS *(Ordinances, Resolutions, Public Hearings)*

4. Resolution No. 7316 – Accepting and Approving the FY 2022 Audit *(Toby Spears, Finance Director; Farley Vener, CPA, CFE, Hinkle + Landers, P.C.)*
5. Consideration of Approval of a Sole Source Purchase from ZeroEyes, Inc., for Weapon Detection Service in the Amount of \$117,500.00 *(Christa Belyeu, I. T. Director)*
6. Resolution No. 7317 – Determining that Certain Structures are Ruined, Damaged and Dilapidated, are a Menace to Public Comfort, Health and Safety and Requires Removal from the Municipality (2604 West Texas and 712 South Selman) *(Valerie Chacon, Deputy City Attorney and Jessica Silva, Code Enforcement Superintendent)*
7. **PUBLICATION:** Proposed Ordinance Amending Chapter 1 of the Hobbs Municipal Code Establishing Non-Traffic Penalty Assessments *(Valerie Chacon, Deputy City Attorney)*
8. **PUBLICATION:** Proposed Ordinance Amending Chapter 10 of the Hobbs Municipal Code Prohibiting Parking of Heavy Trucks and Trailers on Streets *(Efren Cortez, City Attorney)*
9. Consideration of Approval of a Contract with Stantec Consulting Services, Inc., Pursuant to RFP No. 538-23 for College Lane Widening and Realignment Project in the Amount of \$235,729.74 *(Todd Randall, City Engineer)*
10. Consideration of Approval of a CES Contract with Guadalupe Mountain Fencing in the Amount of \$253,666.80 for the Installation of New Decorative Ornamental Fencing on the East and South Side of Prairie Haven Cemetery *(Bryan Wagner, Parks & Open Spaces Director)*

COMMENTS BY CITY COMMISSIONERS, CITY MANAGER

11. Next Meeting Date:

- City Commission Regular Meeting:
 - **Monday, April 3, 2023, at 6:00 p.m.**

ADJOURNMENT

If you are an individual with a disability who needs a reader, amplifier, qualified sign language interpreter, or any other form of auxiliary aid or service to attend or participate in the above meeting, please contact the City Clerk's Office at (575) 397-9200 at least 72 hours prior to the meeting or as soon as possible. Public documents, including the agenda and minutes, can be provided in various accessible formats. Please contact the City Clerk's Office if a summary or other type of accessible format is needed.



CITY OF HOBBS
COMMISSION STAFF SUMMARY FORM

MEETING DATE: March 20, 2023

SUBJECT: City Commission Meeting Minutes

DEPT. OF ORIGIN: City Clerk's Office
DATE SUBMITTED: March 13, 2023
SUBMITTED BY: Jan Fletcher, City Clerk

Summary:

The following minutes are submitted for approval:

- Regular Commission meeting held on March 6, 2023

Fiscal Impact:

Reviewed By: Finance Department

N/A

Attachments:

Minutes as referenced under "Summary".

Legal Review:

Approved As To Form: City Attorney

Recommendation:

Motion to approve the minutes as presented.

Approved For Submittal By:

Handwritten signature and lines for Department Director and City Manager

CITY CLERK'S USE ONLY
COMMISSION ACTION TAKEN

Resolution No., Ordinance No., Approved, Other, Continued To, Referred To, Denied, File No.

Minutes of the regular meeting of the Hobbs City Commission held on Monday, March 6, 2023, in the City Commission Chamber, 200 East Broadway, 1st Floor Annex, Hobbs, New Mexico. This meeting was also available to the public via Livestream on the City's website at www.hobbsnm.org.

Call to Order and Roll Call

Mayor Sam Cobb called the meeting to order at 6:00 p.m. and welcomed everyone to the meeting. The City Clerk called the roll and the following answered present:

Mayor Sam D. Cobb
Commissioner R. Finn Smith
Commissioner Christopher Mills
Commissioner Larron B. Fields
Commissioner Joseph D. Calderón
Commissioner Dwayne Penick
Commissioner Don Gerth

Also present:

Manny Gomez, City Manager
Efren Cortez, City Attorney
Valerie Chacon, Deputy City Attorney
August Fons, Police Chief
Shane Blevins, Deputy Police Chief
Danny Garrett, Police Captain
Chad Wright, Police Captain
Ricky Guerrero, Police Captain
Jessica Silva, Code Enforcement Supt.
Barry Young, Fire Chief
Mark Doporto, Deputy Fire Chief
Kevin Shearer, Fire Battalion Chief
Adam Marinovich, Fire Captain
Tony Alarcon, Fire Inspector
Nicholas Goulet, Human Resources Director
Tracy South, Assistant Human Resources Director
Toby Spears, Finance Director
Bob Hamilton, Acting Library Director
Anthony Henry, Deputy City Engineer
Tim Woomer, Utilities Director
Julie Nymeyer, Executive Assistant
Bryan Wagner, Parks and Open Spaces Director
Matt Hughes, Rockwind Golf Course Superintendent
Doug McDaniel, Recreation Director
Christa Belyeu, I.T. Director
Meghan Mooney, Communications Director
Selena Estrada, Risk Manager
Alicia Jacobs, Clerk Record Specialist
14 citizens

Invocation and Pledge of Allegiance

Commissioner Penick delivered the invocation and Commissioner Smith led the Pledge of Allegiance.

Approval of Minutes

Commissioner Calderón moved the minutes of the work session of February 21, 2023, regular meeting of February 21, 2023, and the work session of February 22, 2023, be approved as written. Commissioner Gerth seconded the motion and roll call vote was recorded as follows: Smith yes, Penick yes, Calderón yes, Fields yes, Mills yes, Gerth yes, Cobb yes. The motion carried.

Proclamations and Awards of Merit

None.

Public Comments

Ms. Ashley Rodriguez of Hearts Desire introduced herself and provided an overview of the work of the non-profit organization. She stated the entity provides addiction counseling and recovery services for Lea County. Ms. Rodriguez inquired about obtaining permission for this non-profit organization to use the CORE without charge. Mayor Cobb thanked Ms. Rodriguez and suggested she speak with Mr. Manny Gomez, City Manager, and Mr. Doug McDaniel, Recreation Director, about her inquiry.

Mr. Nick Maxwell addressed several comments to the Commission including appreciation for the work of Hearts Desire, questions that need to be asked regarding condemnation of properties, his objection to ELEA and public meetings with elected officials which need to be open to the public to attend.

Consent Agenda

None.

Discussion

Law Enforcement Assisted Diversion (LEAD) Update

Ms. Jessica Owen of LEAD and Sgt. Matthew Burleson of the Hobbs Police Department (HPD) presented an updated about the LEAD Program. Ms. Owen stated Sgt. Burleson and Officer Maxwell of the HPD have been true champions of the program. She stated 24 referrals, 12 male and 12 female, have been made to the program and 20 are enrolled. The program has an 83% success rate which is the highest in the State. Ms. Owen stated she attended a summit with representatives

from HPD and 300 other participants to learn new action plans to help the program succeed. She stated other municipalities in Lea County and the New Mexico State Police are interested in the program.

Sgt. Burleson stated the success of the program, thus far, has definitely been a community wide team effort.

Mayor Cobb wished LEAD continued success and thanked the presenters for the update.

Golf Fee Survey Results

Mayor Cobb stated the City of Hobbs has not had any changes to its golf fee structure since 2015. He requested City staff to review those fees and report back to the Commission with the results.

Mr. Doug McDaniel, Recreation Director, and Mr. Ben Kirkes, Rockwind Golf Professional, presented the results of the informal golf fee survey to the Commission. Mr. McDaniel stated there is not a one-size-fits-all golf fee structure which can be used.

Mr. Kirkes stated 18 golf courses were reviewed. He presented the data collected from the golf courses, a copy of which is attached; and stated three categories were used in compiling the data:

- Courses that are similar in ranking by golf publications (Golf Week, Golf Digest and Golf Pass);
- Courses that are similar in Course Rating (difficulty and build); and
- Courses in the same regional area as Rockwind Community Links (our competition).

Mr. Kirkes stated Rockwind Community Links has 70 different golf fees. He stated some golf courses use a dynamic pricing concept, such as the Lubbock area, who increase the cost for a round of golf during Texas Tech game days. Mr. Kirkes reviewed the fees for five golf courses with similar rankings as Rockwind:

1. Twin Warriors Golf Club
2. Pinon Hills Golf Club
3. Sandia Golf Club
4. Red Hawk Golf Club
5. Black Mesa Golf Club

Mr. Kirkes reviewed fees for five golf courses similar in course rating as Rockwind:

1. UNM Championship Golf Course
2. New Mexico State University Golf Course
3. The Rawls Course at Texas Tech
4. Santa Ana Golf Club
5. Painted Dunes Desert Golf Club

Mr. Kirkes reviewed fees from the following courses that are regional courses close in location to Rockwind:

1. Lake Carlsbad Golf Course
2. Nancy Lopez Golf Club at Spring River
3. Gaines County Golf Club
4. Hogan Park Golf Club
5. Ratliff Ranch Golf Course
6. Nueva Vista Golf Course
7. Yoakum County Golf Course

Mr. Kirkes reviewed the current fee structure for Rockwind Community Links.

Mr. McDaniel provided a fee comparison worksheet, a copy of which is attached to these minutes, showing that Rockwind Community Links is No. 16 of 18 golf courses for the daily/weekday greens fee for 18 holes with golf cart. Rockwind is No. 9 of 10 courses in fee comparison for a daily/weekday greens fee for 18 holes for a walking adult golfer. Rockwind is No. 7 of 8 courses for daily/weekday greens fee for a walking senior golfer. Rockwind is No. 6 of 6 courses for a daily/weekday greens fee for a senior golfer using a golf cart.

A lengthy discussion was held on the use of dynamic fees for Rockwind and the need for a rate increase. Mayor Cobb stated the cost of operating the golf course has increased. In answer to Mayor Cobb's question, Mr. Toby Spears, Finance Director, stated the current subsidy level is \$1.8 million. Mayor Cobb stated the needs to be realistic while adjustment the fee and take a good balanced approach to the situation.

Commissioner Penick suggested the City be careful in not raising the fee too high to avoid dropping participation levels at the golf course and to continue to make it affordable for senior golfers.

In response to Commissioner Mills' question, Mr. Kirkes stated 22,000 rounds of golf were played last year. Commissioner Mills commented that the City contributes \$81.00 for every round of golf played by a golfer.

Mr. Gomez stated this item is for discussion only as he had requested staff to review the fees since they have not been adjusted since 2015.

Commissioner Gerth stated some golfers who only receive Social Security income may not be able to afford an increase in the golf fees.

In response to Commissioner Fields' question, Mr. McDaniel stated Hobbs is at the bottom of the list on fee charges.

Mr. Efren Cortez, City Attorney, stated the Hobbs Municipal Code requires any changes to proposed fees must first be discussed by the Commission in an open meeting. Any changes must then be approved by resolution of the Commission at a subsequent meeting.

Mayor Cobb stated staff was requested to review the fees. He stated it is the City's fiduciary responsibility to be fair to all of the taxpayers. The golf facility will soon be eight years old and the City must be cognizant of increased operational costs, replacement costs and aging components. Minor adjustments can be made to the fee structure but it is the City's obligation to address the issue.

Mr. McDaniel stated the City has many fees in its rate structure. Mayor Cobb stated there is a need to simplify the rate structure as it is becoming difficult to manage.

Mayor Cobb thanked Mr. McDaniel and Mr. Kirkes for the information provided.

Action Items

Resolution No. 7314 – Determining that Certain Structures are Ruined, Damaged and Dilapidated, are a Menace to Public Comfort, Health and Safety and Requires Removal from the Municipality (2604 West Texas, 712 South Selman, 1408 East Humble, and 306 South McKinley)

Mayor Cobb stated Ms. Rosa Carrasco is present tonight to speak to the Commission regarding condemnation of the property at 306 South McKinley. Another citizen in the audience stated they are present to speak tonight related to 1408 East Humble. Due to a pending presentation elsewhere by the City Attorney's Office, Mayor Cobb requested a motion to table action on the properties at 2604 West Texas and 712 South Selman.

Commissioner Penick moved that action on the properties at 2604 West Texas and 712 South Selman be tabled tonight. Commissioner Calderón seconded the motion and roll call vote was recorded as follows: Smith yes, Penick yes, Calderón yes, Fields yes, Mills yes, Gerth yes, Cobb yes. The motion carried.

Ms. Valerie Chacon, Deputy City Attorney, stated properties have been identified which present health, life and safety hazards which warrant remediation. The first property is located at 306 South McKinley which is owned by Teodoro V. Ortiz and Rosa Carrasco. Ms. Chacon displayed photographs of the mobile home and property. She stated it is located across the street from the Hobbs Fire Department, Station 1. Notice was sent to the property owner on August 8, 2022, and a second letter was sent last month. Ms. Chacon stated the City's goal is always to seek voluntary compliance from all property owners related to clean up of their properties.

Ms. Rosa Carrasco, property owner, stated she was not aware of the condition of the property did not realize until this week that she was the owner of the property. She agreed that the property is dilapidated and people have been staying inside the property and have stolen some of her belongings. Ms. Carrasco stated she would like someone to haul off the entire mobile home.

In response to Mayor Cobb's question, Ms. Carrasco stated she was informed by Ms. Chacon she could have two weeks to remove her belongings and then 30 days thereafter to demolish and remove the mobile home. Ms. Chacon agreed.

Commissioner Penick suggested to Ms. Carrasco she might consider placing an ad in the newspaper that it's "free" for someone to haul off.

Mayor Cobb stated he is fine with staff's recommendation.

Commissioner Calderón moved that the property at 306 South McKinley be determined as ruined, damaged and dilapidated allowing two weeks for the property owner to remove her belongings and 30 days from the date of publication to demolish and remove the mobile home. Commissioner Gerth seconded the motion and roll call vote was recorded as follows: Smith yes, Penick yes, Calderón yes, Fields yes, Mills yes, Gerth yes, Cobb yes. The motion carried. Copies of the resolution and supporting documentation are attached.

Ms. Chacon stated the next property for consideration by the Commission is 1408 East Humble. She displayed photographs of the property owned by Dollie and Lloyd Fagan, both of whom are deceased. Ms. Chacon stated there is extensive fire damage to the property.

Ms. Theresa Walker, a nearby neighbor, spoke in support of removal of the structure. She stated squatters have dug holes inside the structure where they were burning fires to keep warm.

Commissioner Calderón moved that the property at 1408 East Humble be determined as ruined, damaged and dilapidated. Commissioner Fields seconded the motion and roll call vote was recorded as follows: Smith yes, Penick yes, Calderón yes, Fields

yes, Mills yes, Gerth yes, Cobb yes. The motion carried. Copies of the resolution and supporting documentation are attached.

Resolution No. 7315 - Authorizing Approval to Submit a Grant Application to the Department of Homeland Security and the Federal Emergency Management Agency for the Staffing for Adequate Fire and Emergency Response (SAFER) Grant for the Hobbs Fire Department

Mr. Barry Young, Fire Chief, explained the resolution and stated the Hobbs Fire Department is eligible for funding to increase the number of firefighters to help meet industry minimum standards, to attain staffing to provide adequate protections from fire and fire-related hazards, and to fulfill the mission of the Fire Department. The SAFER grant provides three-year grants to assist fire departments by paying the salaries and benefits of the SAFER-funded positions. Chief Young stated the Hobbs Fire Department wishes to apply for the funding of six firefighter positions to be funded 100% through the grant with no local match. After three years, the City would then be fully responsible for all costs associated with the positions.

Commissioner Smith moved that Resolution No. 7315 be adopted as presented. Commissioner Mills seconded the motion and roll call vote was recorded as follows: Smith yes, Penick yes, Calderón yes, Fields yes, Mills yes, Gerth yes, Cobb yes. The motion carried. Copies of the resolution and supporting documentation are attached.

FINAL ADOPTION: Ordinance No. 1148 - Amending Section 15.04.020 of the Hobbs Municipal Code to Incorporate the 2021 International Fire Code

Chief Young explained the proposed ordinance to adopt the 2021 International Fire Code. It was first presented to the Commission on February 6, 2023, and subsequently published in the Hobbs News-Sun on February 14, 2023. Chief Young stated the Fire Department has not received any comments regarding the published ordinance.

Proper publication having been made, and there being no comments from the audience or discussion, Commissioner Penick moved that Ordinance No. 1148 be adopted as presented. Commissioner Fields seconded the motion and roll call vote was recorded as follows: Smith yes, Penick yes, Calderón yes, Fields yes, Mills yes, Gerth yes, Cobb yes. The motion carried. A copy of the ordinance is attached.

FINAL ADOPTION: Ordinance No. 1149 - Amending Chapter 8.32 of the Hobbs Municipal Code Amending the City's Fire Code Ordinance

Chief Young explained the proposed ordinance to adopt the 2021 International Fire Code. It was first presented to the Commission on February 6, 2023, and subsequently published in the Hobbs News-Sun on February 14, 2023. Chief Young stated the Fire Department has not received any comments regarding the published ordinance.

Proper publication having been made, and there being no comments from the audience or discussion, Commissioner Gerth moved that Ordinance No. 1149 be adopted as presented. Commissioner Calderón Fields seconded the motion and roll call vote was recorded as follows: Smith yes, Penick yes, Calderón yes, Fields yes, Mills yes, Gerth yes, Cobb yes. The motion carried. A copy of the ordinance is attached.

COMMENTS BY CITY COMMISSIONERS, CITY MANAGER

Mr. Gomez stated Coffee with Cops will be held on March 8, 2023, at Habitat for Humanity located at 301 North Navajo.

Mr. Gomez announced that Xcel Energy and subcontractors will be working on pulling transmission lines across Navajo near the Seminole Highway which could result in traffic delays.

Ms. Meghan Mooney, Communications Director, reported on the Swing Fore Nine Golf Tournament held at Rockwind Community Links during the weekend. She stated the event was very successful honoring the lives lost in a horrific car accident with approximately \$60,000 earned during the tournament, sponsorship money and silent auction proceeds. Ms. Mooney stated the event was covered by several media outlets and plans for the tournament next year are underway. She thanked the Commission for its support of the event.

Mayor Cobb stated this event has national potential for all the right reasons, including the PGA and LPGA. He added it could become a pro-am tournament.

Commissioner Mills thanked the Hobbs Police Department for the recent virtual reality training he attended. He stated the training value was great.

Commissioner Fields agreed. He expressed appreciation to the Hobbs Fire Department for their professionalism and expertise during a recent fire.

Commissioner Penick stated the training scenario with the Hobbs Police Department was very valuable. He also commended the Hobbs Fire Department for the new professional look of their uniforms.

Mayor Cobb stated he and Mr. Gomez traveled round trip to Santa Fe on Friday to meet with legislators. He announced that the Senate Finance Committee approved a bill which would provide a one-time payment of \$25 million to the City of Hobbs. Mayor Cobb stated there is still work to do prior to the end of the session on March 18, 2023.

Adjournment

There being no further business or comments, Commissioner Calderón moved that the meeting adjourn. Commissioner Gerth seconded the motion and the vote was recorded as follows: Smith yes, Penick yes, Calderón yes, Fields yes, Mills yes, Gerth yes, Cobb yes. The motion carried. The meeting adjourned at 7:20 p.m.

SAM D. COBB, Mayor

ATTEST:

JAN FLETCHER, City Clerk

PROCLAMATIONS

AND

**AWARDS OF
MERIT**

March Milestones 2023

5 years

Beatriz Hernandez	POSD	03/26/2018
Barry Muniz	CORE	03/05/2018

15 years

Shane Cox	Waste Water	03/24/2008
-----------	-------------	------------

30 years

Roberto Gonzalez	Senior Center	03/22/1993
------------------	---------------	------------

35 years

Tommy Trevino	Building Maintenance	03/31/1988
---------------	----------------------	------------



ACTION ITEMS



CITY OF HOBBS
COMMISSION STAFF SUMMARY FORM

MEETING DATE: March 20, 2023

SUBJECT: Resolution accepting and approving the FY2022 Audit.
DEPT. OF ORIGIN: Finance Department
DATE SUBMITTED: 03/01/2023
SUBMITTED BY: Deborah Corral, Assistant Finance Director

Summary:

The City of Hobbs is required by statute to contract with an independent auditor to perform the required annual audit. The audit has been completed by Hinkle + Landers, PC and the NM Office of the State Auditor has authorized the release of this audit per their release letter dated February 21, 2023.

Per NMAC 2.2.2.10 (M) (4), once the report is released and a 5 day waiting period has passed, the audit shall be presented by the independent audit firm to a quorum of the governing authority at a meeting held in accordance with the Open Meetings Act.

This resolution is seeking acceptance and approval of the completed FY22 audit report and findings.

Fiscal Impact:

No fiscal impact.

Reviewed By: _____

[Signature]
Finance Department

Attachments: Resolution

Legal Review:

Approved As To Form: _____

[Signature]
City Attorney

Recommendation:

Approval of resolution.

Approved For Submittal By:

[Signature]
Department Director

[Signature]
City Manager

CITY CLERK=S USE ONLY
COMMISSION ACTION TAKEN

Resolution No. _____
Ordinance No. _____
Approved _____
Other _____

Continued To: _____
Referred To: _____
Denied _____
File No. _____

CITY OF HOBBS

RESOLUTION NO. 7316

**RESOLUTION OF ACCEPTANCE AND
APPROVAL OF THE FY22 AUDIT**

WHEREAS, the City of Hobbs is required by statute to contract with an independent auditor to perform the required annual audit or agreed upon procedures for Fiscal Year 2022; and,

WHEREAS, the City of Hobbs has directed the accomplishment of the audit for FY22 be completed; and,

WHEREAS, this audit has been completed and presented to the Hobbs City Commission per the February 21, 2023 letter from the State Auditor authorizing release of the FY22 audit.

WHEREAS, NMAC 2.2.2.10 (M) (4) provides in pertinent part that “Once the audit report is officially released to the agency by the state auditor (by a release letter) and the required waiting period of five calendar days has passed, unless waived by the agency in writing, the audit report shall be presented by the IPA, to a quorum of the governing authority of the agency at a meeting held in accordance with the Open Meetings Act, if applicable;” and,

NOW THEREFORE, BE IT RESOLVED, that the Hobbs City Commission does hereby accept and approve the completed audit report and findings as indicated within this document.

ACCEPTED AND APPROVED this **20th** day of **March 2023**, in regular session by the Hobbs City Commission, at Hobbs, Lea County, New Mexico.

SAM D. COBB, Mayor

R. FINN SMITH, Commissioner

CHRISTOPHER MILLS, Commissioner

LARRON B. FIELDS, Commissioner

JOSEPH D. CALDERÓN, Commissioner

ROY DWAYNE PENICK, Commissioner

DON R. GERTH, Commissioner

ATTEST BY:

JAN FLETCHER, City Clerk

BRIAN S. COLÓN, ESQ. CFE
STATE AUDITOR



Liza Kerr, CPA, CISA, CIA Elena
Tercero, CPA, CGFM, CGMA
CO-DEPUTY STATE AUDITORS

State of New Mexico
Office of the State Auditor

CONSTITUENT SERVICES
(505) 476-3821

Via: Email

2/21/2023
Toby Spears, Finance Director
tspears@hobbsnm.org
City of Hobbs

OSA Ref No. 6086

Re: Authorization to Release 2022 City of Hobbs Audit Report

The Office of the State Auditor (Office) received the audit report for your agency on 12/12/2022. The OSA has completed the review of the audit report required by Section 12-6-14(B) NMSA 1978 and any applicable provisions of the Audit Rule. This letter is your authorization to make the final payment to the Independent Public Accountant (IPA) who contracted with your agency to perform the financial and compliance audit. In accordance with the audit contract, the IPA is required to deliver to the agency the number of copies of the report specified in the contract.

Pursuant to Section 12-6-5 NMSA 1978, the audit report does not become a public record until five days after the date of this release letter, unless your agency has already submitted a written waiver to the OSA. Once the five-day period has expired, or upon the OSA's receipt of a written waiver:

- the OSA will send the report to the Department of Finance and Administration, the Legislative Finance Committee and other relevant oversight agencies;
- the OSA will post the report on its public website; and
- the agency and the IPA shall arrange for the IPA to present the report to the governing authority of the agency, per the Audit Rule, at a meeting held in accordance with the Open Meetings Act, if applicable.

Although no findings were reported in your report, please remember it is ultimately the responsibility of the governing authority of the agency to maintain adequate internal controls over financial reporting and compliance.

Sincerely,

A handwritten signature in blue ink that reads "Brian S. Colón".

Brian S. Colón, Esq. CFE
State Auditor

cc. Hinkle + Landers, PC



CITY OF HOBBS

COMMISSION STAFF SUMMARY FORM

MEETING DATE: March, 20, 2023

SUBJECT: Purchase ZeroEyes Weapon Detection Service
DEPT. OF ORIGIN: Information Technology Department
DATE SUBMITTED: March 9, 2023
SUBMITTED BY: Christa Belyeu, IT Director

Summary:

The IT Department is requesting to purchase a weapon detection service that will integrate with our existing camera systems. This solution would be purchased from ZeroEyes, Inc. and be a 60 month contract. ZeroEyes uses AI technology to detect and identify weapons (guns, rifles, shotguns). This is a sole source purchase, and was posted on February 6, 2023.

Fiscal Impact:

Reviewed By: [Signature]
Finance Department

Digitally signed by Toby Spears, CFE, CPA
DN: cn=Toby Spears, CFE, CPA, o=City of
Hobbs, ou=Finance Director,
email=tobyspears@hobbsnm.org, c=US
Date: 2023.03.07 13:52:17 -0700

\$27,500 is in the FY23 budget for this project. The project total for 60 months is \$117,500.00.

Onetime costs of the upgrade include (included in year 1):

- \$5,000.00 Security & network Infrastructure Integration (Platform Fee)

There are also recurring costs associated with this project:

- \$22,500.00 annually for years 2-5

Additional costs are not projected, but could be incurred pending necessary camera upgrades or replacements.

Attachments:

Quote – HobbsNM_Quote_030123_AH.pdf

Legal Review:

Approved As To Form: [Signature]
City Attorney

Recommendation:

Motion to approve the resolution.

Approved For Submittal By:

Christa Belyeu Digitally signed by Christa Belyeu
DN: cn=Christa Belyeu, o=City of Hobbs,
ou=Information Technology Department, c=US
Email: cbelyeu@hobbsnm.org

Department Director

[Signature]
City Manager

CITY CLERKS USE ONLY
COMMISSION ACTION TAKEN

Resolution No. _____

Ordinance No. _____

Approved _____

Other _____

Continued To: _____

Referred To: _____

File No. _____

Denied



ZeroEyes , Inc.
555 E North Ln, Suite 5050
Conshohocken, PA 19428

Sales Quote / Order Form

Quote Create Date: 3/1/2023

Quote Exp. Date: 3/31/2023

Quote No: 00001

Bill to:

City of Hobbs
200 East Broadway
Hobbs, NM 88240

Term - 60 months	# of Camera Streams	Subtotal
Weapon Detection Service - Year 1	Up to 75 (\$25/camera stream/month)	\$22,500.00
Weapon Detection Service - Year 2	Up to 75 (\$25/camera stream/month)	\$22,500.00
Weapon Detection Service - Year 3	Up to 75 (\$25/camera stream/month)	\$22,500.00
Weapon Detection Service - Year 4	Up to 75 (\$25/camera stream/month)	\$22,500.00
Weapon Detection Service - Year 5	Up to 75 (\$25/camera stream/month)	\$22,500.00
Security & Network Infrastructure Integration (Platform Fee)		\$5,000.00
Total		\$117,500.00

*If paying on an annual basis "Platform Fee" will be added to 1st year's cost.

*Service Year 1 will begin once install is complete and the system has been tested and is functioning properly.

*If the City of Hobbs decides to renew service at the end of this agreement rates, terms and conditions will be negotiated at that time.

Customer Signature / Customer Name (typed) / Date
City of Hobbs

Company Signature / Company Name (typed) / Date
ZeroEyes, Inc.

TERMS AND CONDITIONS

1. **By signing this Sales Quote, the Customer has read, acknowledged, and agreed to the terms and conditions set forth in the Subscription Agreement here: <https://zeroeyes.com/saas-agreement/>.**
2. Pricing is strictly confidential.
3. Maximum of ten application users up to 500 cameras. Can add one additional user for every 50 cameras purchased beyond 500.
4. If you have any questions on this proposal, feel free to contact Adam Horn, VP of Government Solutions, at your convenience by email at: adamhorn@zeroeyes.com.

WE WILL BE IN TOUCH WITH YOU SOON TO ARRANGE A FOLLOW-UP CONVERSATION REGARDING THIS PROPOSAL.
THANK YOU FOR YOUR CONSIDERATION.



CITY OF HOBBS
COMMISSION STAFF SUMMARY FORM

MEETING DATE: March 20, 2023

SUBJECT: Condemnation Recommendation on Certain Properties

DEPT. OF ORIGIN: City of Hobbs Legal Department, Hobbs Police Department - Community Services Division

DATE SUBMITTED: March 10, 2023

SUBMITTED BY: Valerie S. Chacon, Deputy City Attorney, Jessica Silva Code Enforcement Superintendent

Summary:

In its continuing promotion of safety and clean-up efforts within city limits, the Hobbs Police Department-Community Services Division has identified properties which present health, life and safety hazards, which warrant remediation. The properties are in dire need of repair. The properties are located at 2604 W. Texas, and 712 S. Selman are ruined, damaged and dilapidated and a menace to the public comfort, health and safety. Attachment A contains the information for the properties.

Fiscal Impact:

Reviewed By: [Signature] Finance Department

The demolition and clean-up of these properties will cost approximately \$61,969.23. The current budget in the "Professional Services" line item of the Environmental Budget (01340-42601) has an adequate balance to sustain this expenditure.

Attachments:

- 1. Resolution
2. Photos of properties contained in Attachment "A".
3. Attachment "A"

Legal Review:

Approved As To Form: [Signature] City Attorney

Recommendation:

The City Commission approve the adoption of the Resolution determining 2604 W. Texas and 712 S. Selman as ruined, damaged and dilapidated and a menace to public health and safety, which require remediation.

Approved For Submittal By:

[Signature] Department Director

[Signature] City Manager

CITY CLERK'S USE ONLY
COMMISSION ACTION TAKEN

Resolution No. _____ Continued To: _____
Ordinance No. _____ Referred To: _____
Approved _____ Denied _____
Other _____ File No. _____

CITY OF HOBBS

RESOLUTION NO. 7317

A RESOLUTION DETERMINING THAT CERTAIN PROPERTIES THAT ARE RUINED, DAMAGED AND DILAPIDATED, ARE A MENACE TO PUBLIC COMFORT, HEALTH AND SAFETY AND REQUIRE REMEDIATION OR REMOVAL FROM THE MUNICIPALITY

WHEREAS, pursuant to Section 8.24.010 of the Hobbs Municipal Code, and Section 3-18-5 NMSA as amended, the City has inspected the premises described in Attachment "A", attached hereto and incorporated herein by reference, and finds that the structure thereon are ruined, damaged, and dilapidated, are a menace to the public comfort, health and safety and requires removal from the municipality.

NOW, THEREFORE, BE IT RESOLVED BY THE GOVERNING BODY OF THE CITY OF HOBBS, NEW MEXICO, that the structures described in Attachment "A" are found to be ruined, damaged and dilapidated, are a menace to the public comfort, health and safety, and should be removed.

BE IT FURTHER RESOLVED that a copy of this Resolution be served on the owner, occupant or agent in charge of such premises; and that a copy of the same be published as required by law.

BE IT FURTHER RESOLVED that unless the owner, occupant or agent in charge of such premises, within ten (10) days from such service or posting and publication of this Resolution, has commenced removing such structures from the real

property or has filed written objection with the City, the City shall cause the removal of such structures at the cost and expense of the property owner.

BE IT FURTHER RESOLVED that in cases where the City removes a structure so condemned, a lien shall be levied by the City against the real property involved in an amount equal to the reasonable cost of the services rendered, which lien may be foreclosed in default of satisfaction.

PASSED, ADOPTED AND APPROVED this 20TH day of March, 2023

SAM D. COBB, Mayor

ATTEST:

JAN FLETCHER, City Clerk

Attachment A

	Address	Owner	Owner's Address	Estimated Cost of Demolition
1	<p>2604 W. Texas Hobbs, Lea County, NM</p> <p>*A tract of land located the Southwest Quarter of the Northeast Quarter (SW1/ 4NE1 / 4) of Section 5, Township 19 South, Range 38 East, N.M.P.M., Lea County, New Mexico and being more particularly described as follows: Beginning West 1440.7 feet East Quarter Corner of the said Section 5, thence West 211 feet, N0 4'E 349.99 feet, thence S89 56'E 211 feet, thence S0 4'W 349.62 feet to the point of beginning</p>	<p>J.F. Morphis, Earlene Morphis, Judy E. Morphis & Deborah Jo West</p>	<p>6322 W. Potter Dr. Glendale, AZ, 85308</p> <p>6238 N. 10th St. Phoenix, AZ, 85014</p>	\$50,356.58
2	<p>712 S. Selman Hobbs, Lea County, NM</p> <p>*Lot Thirteen (13), Block Thirty (30), New Hobbs Addition to the City of Hobbs, Lea County, New Mexico, as referenced on that certain Plat filed August 26, 1930.</p>	<p>Lazaro Bueno Jr., Raul Ortega Bueno, Luz Dibina Buena "AKA" Luz Divina Rojas, Jose Bueno, Ramona Ortega, & Larzaro Bueno Jr. ETAL</p>	<p>510 E. Gypsy Hobbs, NM, 88240</p> <p>2908 N. Houston Hobbs, NM, 88240</p> <p>1314 E. Byers Hobbs, NM, 88240</p> <p>602 E. Humble Hobbs, NM, 88240</p>	\$11,612.65

2604 W. Texas

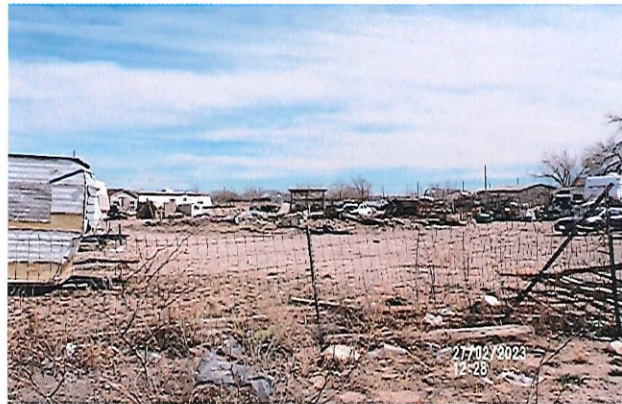

2604 W. Texas



2604 W. Texas



712 S. Selman



712 S. Selman





CITY OF HOBBS
COMMISSION STAFF SUMMARY FORM

MEETING DATE: March 20, 2023

SUBJECT: PUBLICATION OF AN ORDINANCE AMENDING CHAPTER 1 OF THE HOBBS MUNICIPAL CODE ESTABLISHING NON-TRAFFIC PENALTY ASSESSMENTS

DEPT. OF ORIGIN: City Attorney's Office
DATE SUBMITTED: March 13, 2023
SUBMITTED BY: Valerie S. Chacon, Deputy City Attorney

Summary:

NMSA 1978, §§3-17-1, and 3-18-1 confer general welfare and police powers on the City of Hobbs. Additionally, the Constitution of New Mexico Art. X, §6(D) grants powers to home rule municipalities to enact civil laws governing civil relationships incident to the exercise of an independent municipal power. Additionally, staff for the City of Hobbs have identified various sections of the Hobbs Municipal Code that if violated, should not warrant incarceration for any amount of time, and should not constitute a criminal conviction. Pursuant to that authority, the proposed ordinance would make it a penalty assessment to violate the specific sections of the Hobbs Municipal Code so designated as non-traffic penalty assessments by the City Commission. This means a fine only would apply and no jail time could be imposed if the person is found to have committed the violation. The proposed ordinance sets out the necessary citation procedures.

Fiscal Impact:

There is no fiscal impact for this Ordinance.

Reviewed By: _____

[Signature]
Finance Department

Attachments:

Proposed Ordinance.

Legal Review:

Approved As To Form: _____

[Signature]
City Attorney

Recommendation:

The Commission should consider publication of the proposed Ordinance.

Approved For Submittal By: _____

[Signature]
Department Director

[Signature]
City Manager

CITY CLERK'S USE ONLY
COMMISSION ACTION TAKEN

Resolution No. _____
Ordinance No. _____
Approved _____
Other _____

Continued To: _____
Referred To: _____
Denied _____
File No. _____

CITY OF HOBBS

ORDINANCE NO. _____

AN ORDINANCE AMENDING CHAPTER 1 OF THE HOBBS MUNICIPAL CODE
ESTABLISHING NON-TRAFFIC PENALTY ASSESSMENTS

WHEREAS, NMSA 1978, §3-17-1 allows a municipality to adopt ordinances not inconsistent with the laws of New Mexico for the purpose of providing for the safety, preserving the health, promoting the prosperity and improving the morals, order, comfort and convenience of the municipality and its inhabitants; and

WHEREAS, the Constitution of New Mexico Art. X, §6(D) grants powers to home rule municipalities, such as the City of Hobbs, to enact civil laws governing civil relationships incident to the exercise of an independent municipal power; and

WHEREAS, pursuant to the Hobbs Municipal Code Chapter 1.16, a violation of the Hobbs Municipal Code is generally punishable by fine of not more than five hundred dollars (\$500) or imprisonment for not more than ninety (90) days or both; and

WHEREAS, staff for the City of Hobbs have identified various sections of the Hobbs Municipal Code that if violated, should not warrant incarceration for any amount of time, and should not constitute a "criminal conviction"; and

WHEREAS, the Legislature for the State of New Mexico has likewise recognized that certain violations of statutes should not warrant incarceration or constitute a criminal conviction as exemplified by the adoption of NMSA 1978, §31-19A-1, in 2019; and

NOW THEREFORE, BE IT ORDAINED BY THE GOVERNING BODY OF THE CITY OF HOBBS, NEW MEXICO, that Chapter 1, is hereby amended as more specifically described as follows:

TITLE 1

GENERAL PROVISIONS

1.14 – NON-TRAFFIC PENALTY ASSESSMENTS

1.14.010 – Not a conviction

Payment of a fine pursuant to a non-traffic penalty assessment citation shall not be considered a criminal conviction.

1.14.020 – Process for issuance of citation

- A. Whenever a person is issued a non-traffic penalty assessment under the Hobbs Municipal Code, the officer shall advise the person of the option either to accept the penalty assessment and pay it to the court or to appear in court.
- B. The officer, using a uniform non-traffic citation, shall complete the information section, prepare the penalty assessment and prepare a notice to appear in court specifying the time and place to appear.
- C. The citation shall state the address to which the penalty assessment is to be paid if the person accepts the penalty assessment and does not elect to appear in court.
- D. The officer shall have the person sign the citation as a promise either to pay the penalty assessment as prescribed or to appear in court as specified, give a copy of the citation to the person and release the person from custody.
- E. An officer shall not accept custody of payment of any penalty assessment.

1.14.030 – Warning notice permissible

The officer may issue a warning notice, but shall fill in the information section of the citation and give a copy to the person after requiring a signature on the warning notice as an acknowledgment of receipt.

1.14.040 – Signature required

In order to secure release, the person shall give a written promise to appear in court or to pay the penalty assessment prescribed or acknowledge receipt of a warning notice. In cases involving enforcement by officers other than a certified officer with the Hobbs Police Department, inability or refusal of the person to sign the non-traffic citation shall require the officer to file the unsigned citation with the Hobbs Municipal Court and

request a summons be mailed to the person alleged to be in violation of the ordinance in question.

1.14.050 – Jurisdiction and time

- A. The Hobbs Municipal Court shall have jurisdiction for any case arising from a non-traffic penalty assessment under the Hobbs Municipal Code.
- B. A non-traffic penalty assessment citation issued by any officer shall be submitted to the Hobbs Municipal Court within five business days of issuance. If the citation is not submitted within three business days, it may be dismissed with prejudice.

1.14.060 – Failure to appear

- A. A non-traffic citation with a written promise to appear in court or to pay the penalty assessment is a summons. If a person fails to appear or to pay the penalty assessment by the appearance date as outlined on any non-traffic citation or summons, a warrant for failure to appear may be issued.
- B. A written promise to appear in court may be complied with by appearance of counsel.

1.14.070 – Effect and disposition

- A. When a person issued a non-traffic penalty assessment elects to appear in court rather than to pay the non-traffic penalty assessment to the court, no fine imposed upon a later adjudication shall exceed the penalty assessment established for the particular non-traffic penalty assessment.
- B. A person who elects to appear in court shall pay the costs required by law to be collected by the Hobbs Municipal Court.
- C. Payment of any non-traffic penalty assessment must be made to the Hobbs Municipal Court either online, via mail, or in person at 301 N. Turner, Hobbs, New Mexico 88240. Payment of any non-traffic penalty assessment must be made within thirty (30) days from the date of citation. Payments of non-traffic penalty assessments are timely if postmarked within thirty (30) days from the date of citation. The Hobbs Municipal Court may issue a receipt when a non-traffic penalty assessment is paid by currency, but checks tendered by the violator upon which payment is received are sufficient receipt.

1.14.080 – Enforcement authority.

For purposes of this section, "officer" shall include all authorized personnel of the City of Hobbs tasked with enforcement of ordinances contained in the Hobbs Municipal Code.

PASSED, ADOPTED AND APPROVED this ____ day of _____, 2023.

SAM D. COBB, Mayor

ATTEST:

JAN FLETCHER, City Clerk



CITY OF HOBBS
COMMISSION STAFF SUMMARY FORM

MEETING DATE: March 20, 2023

SUBJECT: PUBLICATION OF AN ORDINANCE AMENDING CHAPTER 10 OF THE HOBBS MUNICIPAL CODE PROHIBITING PARKING OF HEAVY TRUCKS AND TRAILERS ON STREETS

DEPT. OF ORIGIN: Legal Department
DATE SUBMITTED: March 13, 2023
SUBMITTED BY: Efren A. Cortez, City Attorney

Summary: NMSA 1978, §§ 3-17-1 and 3-18-1 confer general welfare and police powers on the City of Hobbs. Additionally; NMSA 1978, § 66-7-415 allows a municipality to regulate the operation of commercial motor vehicles with respect to streets under their jurisdiction. The proposed ordinance would make parking any heavy truck (GVWR greater than 26,000 pounds) or any trailer longer than 20 feet (exclusive of the trailer tongue) a penalty assessment misdemeanor. The goal of the proposed ordinance is to decrease the potential for motor vehicle accidents by limiting sight obstructions and diminished travel space on roadways which are often caused by heavy trucks.

Fiscal Impact:

Reviewed By: [Signature]
Finance Department

The estimated cost for the necessary signs is \$4,000.00 for five (5) signs (material only) and adequate funds will be made available within the City Engineer's budget for signals and signs for FY24 (010412-42404).

Attachments:
Proposed Ordinance

Legal Review:

Approved As To Form: [Signature]
City Attorney

Recommendation:

Motion to approve.

Approved For Submittal By:

[Signature] Department Director
[Signature] City Manager

CITY CLERK'S USE ONLY
COMMISSION ACTION TAKEN

Resolution No. _____ Continued To: _____
Ordinance No. _____ Referred To: _____
Approved _____ Denied _____
Other _____ File No. _____

CITY OF HOBBS

ORDINANCE NO. _____

AN ORDINANCE AMENDING CHAPTER 10 OF THE HOBBS MUNICIPAL CODE
PROHIBITING PARKING OF HEAVY TRUCKS AND TRAILERS ON STREETS

WHEREAS, the City of Hobbs has previously adopted the Uniform Traffic Ordinance to govern the traffic laws within the municipal limits of the City of Hobbs, New Mexico, through enactment of an amended Chapter 10 of the Hobbs Municipal Code; and

WHEREAS, NMSA 1978, §3-17-1 allows a municipality to adopt ordinances not inconsistent with the laws of New Mexico for the purpose of providing for the safety, preserving the health, promoting the prosperity and improving the morals, order, comfort and convenience of the municipality and its inhabitants; and

WHEREAS, the Uniform Traffic Ordinance Section 12-6-6.1 authorizes the City Manager, or his or her designee, to erect and maintain signs regulating parking on streets located in the municipal boundaries; and

WHEREAS, City of Hobbs has identified the parking of heavy trucks, as that term is defined by state statute and local ordinance, on the streets of Hobbs, New Mexico to be detrimental to the safety, health, prosperity, morals, order, comfort and convenience of the Hobbs, New Mexico, and its inhabitants; and

NOW THEREFORE, BE IT ORDAINED BY THE GOVERNING BODY OF THE CITY OF HOBBS, NEW MEXICO, that Chapter 10, is hereby amended as more specifically described as follows:

TITLE 10 VEHICLES AND TRAFFIC

10.05 PARKING RESTRICTIONS FOR HEAVY TRUCKS AND TRAILERS

10.05.010 Purpose.

When parked on public streets, heavy trucks and trailers often create sight obstructions and severely limit the surface area of the public street available to other motorists. These conditions increase the probability of motor vehicle accidents. The purpose of this chapter is to protect the safety, health, prosperity, morals, order, and comfort of the residents of Hobbs, New Mexico, by prohibiting heavy trucks and trailers from being parked on public streets within the municipal corporate limits of Hobbs.

10.05.020 Authority.

This chapter is adopted pursuant to NMSA 1978, § 66-7-415, which authorizes the city to prohibit the operation of heavy trucks in addition to the general welfare and police powers conferred upon the City of Hobbs by NMSA, §§ 3-17-1, et seq. and 3-18-1, et seq. Regulation of parking on municipal streets is authorized by Article VI of the Uniform Traffic Ordinance.

10.05.030 Definitions.

For purposes of this chapter, the following definitions shall be in addition to, not exclusive of, the definitions set forth in the Article I of the Uniform Traffic Ordinance:

- A. Public Street: means every way or place generally open to the use of the public as a matter of right for the purpose of vehicular travel, even though it may be temporarily closed or restricted for the purpose of construction, maintenance, repair or reconstruction. For purposes of this chapter, public street shall include the adjacent shoulder, curb, sidewalk, parkway, and right of way.
- B. Heavy Truck: means a Class 7 or larger truck, as defined by the United States Department of Transportation and 49 C.F.R. Section 523, having a Gross Vehicle Weight Rating (GVWR) greater than 26,000 pounds.
- C. Trailer: means any vehicle, with or without power, designed for carrying persons or property and for being drawn by a motor vehicle, and so constructed that no part of its weight rests upon the towing vehicle, hitched or unhitched, longer than 20 feet measured exclusive of the trailer tongue.

10.05.040 Parking heavy trucks and trailers – prohibitions and exceptions.

- A. It shall be unlawful to park any heavy truck on any public street.

- B. It shall be unlawful to park any trailer, as defined herein, whether hitched or unhitched, on any public street. This subsection shall not in any way prohibit enforcement of unhitched trailers pursuant to Section 12-6-13.3 of the Uniform Traffic Ordinance.
- C. Temporary parking of a heavy trucks and trailers is not prohibited when the temporary parking of the heavy truck and trailer is for the purposes of loading, unloading, making pick-up, making deliveries, or providing services.
- D. Parking of authorized emergency vehicles, government vehicles, utility maintenance vehicles, and school buses, are not prohibited when parked on the public street at the residence of the vehicle's operator in light of the potential need to respond to public safety emergencies.

10.05.050 Notice.

- A. Pursuant to Uniform Traffic Ordinance Section 12-6-6.1 the City Manager or his or her designee shall erect and maintain signs designating the provisions of this section throughout the City as he or she deems appropriate. The signs shall be placed in conspicuous locations throughout the City in order to ensure visibility of the signs so as to notify possible commercial motorists and the general public. Placement of the signs contemplated herein shall be at the discretion of the City Manager who may receive recommendations from time to time from the City of Hobbs Planning Board. All signs contemplated by this chapter, at a minimum, be placed at all state highway entrance points into the municipal boundaries of Hobbs, New Mexico, and shall contain language notifying motorists of the possible penalties, including fines and towing, for a violation of this ordinance.
- B. This chapter shall not take effect unless and until such signs are erected and maintained and notice thereof is given in writing to the nearest officer or employee of the motor transportation division of the department of public safety authorized to issue special permits.

10.05.060 Penalty.

Violation of this chapter shall constitute a penalty assessment misdemeanor pursuant to Section 12-6-6.1 of the Uniform Traffic Ordinance, as amended pursuant to subsection C of that provision. The penalty assessment misdemeanor for a violation of this chapter shall be designated as "Parking Violations – Heavy Trucks and Trailers" and the authorized penalty assessment shall be specifically set forth in Section 10.04.050 of the Hobbs Municipal Code.

10.05.070 Citation and removal authorized.

- A. Pursuant to Uniform Traffic Ordinance Section 12-3-3 it is the duty of the Hobbs Police Department to enforce this chapter. Citation procedures are those outlined by Uniform Traffic Ordinance Sections 12-12-12, 12-12-13, and 12-12-4.
- B. Pursuant to Uniform Traffic Ordinance Section 12-12-18(D)(1), an officer or employee of the Hobbs Police Department who is authorized to direct traffic or enforce local parking laws, may order the impoundment of any heavy truck or trailer within the municipal corporate limits, without prior notice to the owner or operator thereof, if the heavy truck or trailer is parked in any of the manners outlined in subsections a through o, including but not limited to the following:
 - 1. The heavy truck or trailer is parked or left standing upon a public street in such a position as to obstruct the normal movement of traffic or in such a condition as to create a hazard to other traffic, which for purposes of this chapter shall include the ingress and egress of any private residential driveway;
 - 2. The heavy truck or trailer is parked so as to block the entrance to a public or private driveway;
 - 3. The heavy truck or trailer is parked within fifteen (15) feet of a fire hydrant, is illegally parked so as to prevent access by firefighting equipment to a fire hydrant, or is illegally parked in a properly designated fire lane;
 - 4. The heavy truck or trailer is parked in a tow-away zone;
 - 5. The heavy truck or trailer is either unattended or disabled and loaded with either a dangerous, flammable, combustible or explosive substance which, either by its presence or load conditions is likely to harm the health or safety of the public and moving the vehicle to a safe, legal location is impractical.
- C. Upon impoundment of any heavy truck or trailer as a result of this subsection, all notice procedures following summary impoundment outlined in Section 12-12-18(E) shall be followed.

PASSED, ADOPTED AND APPROVED this _____ day of _____, 2023.

SAM D. COBB, Mayor

ATTEST:

JAN FLETCHER, City Clerk



CITY OF HOBBS
COMMISSION STAFF SUMMARY FORM

MEETING DATE: March 20th, 2023

SUBJECT: RFP 538-23 COLLEGE LN WIDENING AND REALIGNMENT PROJECT
DEPT. OF ORIGIN: Engineering Department
DATE SUBMITTED: 3-9-2023
SUBMITTED BY: Todd Randall, City Engineer

Summary:

The City of Hobbs Commission approved the Evaluation Committee's scoring recommendations for Request for Proposal (RFP) 538-23 on December 19, 2022 which ranked Stantec Consulting Services Inc. as the most qualified offeror.

City of Hobbs Engineering Department Staff, in collaboration with Lea County Staff, have negotiated a preliminary engineering contract scope, schedule, and price in accordance with City of Hobbs Procurement Policy.

The final deliverable for the preliminary engineering phase of the College Ln. Widening & Realignment Project RFP 538-23 will be a Technical Memorandum issued by Stantec Consulting Services Inc. identifying project recommendations to proceed with final design.

Fiscal Impact:

Reviewed By: [Signature] Finance
Digitally signed by Toby Sporn, CFE, CPA
DN: cn=Toby Sporn, CFE, CPA, o=City of Hobbs, ou=Finance Director, email=tsporn@hobbsnm.org, c=US
Date: 2023.03.10 10:04:08 -0700

Budget Line: 48-4048-44901-00179
Budgeted: \$550,000
Preliminary Engineering Fee: \$217,890.00
NMGRT @ 8.1875%: \$17,839.74
Total Design Fee: \$235,729.74

Attachments:

Professional Services Agreement, Amendment 1, Exhibit B, Exhibit C, and Exhibit D.

Legal Review:

Approved As To Form: Efren A. Cortez City Attorney
Digitally signed by Efen A. Cortez
DN: cn=Efen A. Cortez, o=City of Hobbs, ou=City Attorney's Office, email=ecortez@hobbsnm.org, c=US
Date: 2023.03.10 10:48:56 -0700

Recommendation:

Consideration and Approval of Contract Award for RFP 538-23 to Stantec Consulting Services Inc.

Approved For Submittal By:

TODD RANDALL
Digitally signed by TODD RANDALL
DN: cn=TODD RANDALL, o=CITY OF HOBBS, ou=Engineering
Reason: I am approving the document
Contact Info: 575-337-9237
Date: 2023.03.10 12:01:45 -0700

Department Director

[Signature]
City Manager

CITY CLERKS USE ONLY
COMMISSION ACTION TAKEN

Resolution No. _____ Continued To: _____
Ordinance No. _____ Referred To: _____
Approved _____ Denied
Other _____ File No. _____



PROFESSIONAL SERVICES AGREEMENT

THIS CONTRACT is made the 20 day of MARCH, 2023, by and between the City of Hobbs, New Mexico, a municipal corporation located in Lea County, New Mexico (hereinafter referred to as "City") and STANTEC CONSULTING SERVICES INC., an independent contractor with a business address of 3831 E Lohman Avenue, Suite 200 Las Cruces, New Mexico 88011 (hereinafter referred to as "Contractor").

This Contract (hereinafter referred to as "Agreement") is a:

- Category 1 Contract:** (\$0 – not to exceed \$20,000.00). Purchasing requires good faith efforts to acquire the materials or services at the best obtainable price.
- Category 2 Contract:** (\$20,000.00 - not to exceed \$75,000.00). Purchasing requires three (3) written quotes turned in to the Central Purchasing Office.
- Category 3 Contract:** (\$75,000.00 and over). Purchasing requires formal sealed bids or competitive sealed proposals through the Central Purchasing Office.
- Professional Services Contract under \$75,000.00.** Purchasing requires the direction of the City Manager.
- Professional Services Contract \$75,000.00 and over.** Purchasing requires the direction of the City Manager with City Commission approval, subject to the competitive sealed proposal requirements.
- Exempt Contract under \$75,000.00.** Purchasing requires the direction of the City Manager.
- Exempt Contract \$75,000.00 and over.** Purchasing requires the direction of the City Manager with City Commission approval.

The parties to this Agreement, in consideration of their mutual promises, agree as follows:

1. SCOPE OF SERVICES

Preliminary Engineering Design of College Ln from Grimes Str to Lovington Hwy to include, but not limited to, Surveying, Geotechnical Study, Traffic and Safety Study, Preliminary Drainage Report, Alignment Study and Project. Attached in Exhibit C is a breakdown of the task and estimated costs.

2. STATUS OF CONTRACTOR

Contractor acknowledges that its relationship with City is that of an "independent contractor." Therefore, Contractor shall not be considered an employee or agent of City, nor shall Contractor be eligible to accrue leave, retirement benefits, insurance benefits, use of City vehicles, or any other benefits provided to City employees. Contractor agrees not to purport to bind City of Hobbs unless the Contractor has express written authority to do so, and then only within the strict limits of that authority. Contractor further acknowledges that no benefits pursuant to the Worker's Compensation Laws of the State of New Mexico are available to them for the services contemplated herein. Contractor shall be responsible for securing all licenses and registrations related to their business prior to commencing any work under this Agreement. Contractor shall be solely responsible for all taxes and related reporting requirements. City shall have no liability for the payment of taxes other than gross receipts taxes to be calculated in Contractor's invoices.

3. CONTRACT TERM AND TERMINATION

This Agreement shall be effective from date of execution (as noted on page 1 of this Agreement) and shall end upon completion of all services contemplated herein and final payment for said services, or one year from the date of execution, whichever occurs first. This Agreement may be renewed for up to three additional one-year terms upon written approval from both City and Contractor prior to the expiration of any one-year term. This Agreement may be terminated by either party, at any time with or without cause, upon a minimum of thirty (30) days' advanced written notice to the other party. Except as otherwise allowed or provided under this Agreement, City's sole liability upon such termination shall be to pay for acceptable work performed prior to Contractor's receipt of the notice of termination, if City is the terminating party, or Contractor's sending of the notice of termination, if Contractor is the terminating party; provided, however, that a notice of termination shall not nullify or otherwise affect either party's liability for pre-termination defaults under, or breaches of, this Agreement. Contractor shall submit an invoice for such work within thirty (30) days of receiving or sending the notice of termination. Furthermore, City reserves the right to immediately cancel this Agreement if Contractor violates any provision specifically outlined in Paragraph 10 of this Agreement.

4. PRICE

City shall pay Contractor a total of \$ \$235,729.74 inclusive of New Mexico gross receipts taxes. Contractor shall be responsible for paying all costs associated with performance of duties, including but not limited to, mileage and "wear and tear" of vehicles, and costs of equipment necessary to perform services. Contractor shall submit a monthly invoice for services performed in any given month. Upon receipt of any invoice, City shall render payment for said invoice as soon as practical within fifteen (15) days. If payment is made by mail, the payment shall be deemed tendered on the date it is postmarked. However, City shall not incur late charges, interest, or penalties for failure to make payment within the time specified herein. Contractor and City shall both be required to keep detailed records regarding the services rendered. In the event City disputes an invoice, Contractor shall provide City with records regarding all services rendered. Contractor shall remit all invoices to ATTN: Accounts Payable, 200 E. Broadway Street, Hobbs, NM 88240.

Parties agree that the aggregate amount contemplated by this Agreement, including all contemplated gross receipts taxes, shall not exceed \$ \$235,729.74. All amounts contemplated herein shall include all necessary labor, equipment, materials and all other costs necessary to complete the project as specified herein. Approval and acceptance of Contractor's satisfactory completion of the project shall be a prerequisite to final payment. Nothing contained in this Agreement shall be construed by Contractor as guaranteeing Contractor any minimum amount of work. Contractor, upon final payment of all amounts due under this Agreement, releases City and its officers and employees from all liabilities, claims and obligations whatsoever arising from or under this Agreement. No guarantee of future contracts will be granted to any Contractor.

The terms of this Agreement are contingent upon sufficient appropriations and authorization being given by the City of Hobbs' City Commissioners for the performance of this Agreement. If sufficient appropriations and authorization are not given by the City of Hobbs' City Commissioners, this Agreement shall terminate immediately upon written notice being given by City to Contractor. City's decision as to whether sufficient appropriations are available shall be accepted by Contractor and shall be final. If City proposes an amendment to this Agreement to unilaterally reduce funding, Contractor shall have the option to terminate this Agreement or in its alternative, to agree to the reduced funding within thirty (30) days of receipt of the proposed amendment.

5. INSURANCE REQUIREMENTS

Contractor shall maintain insurance coverage through the duration of this Agreement. Contractor shall provide City with a certificate of insurance coverage for General Liability (GL) in a minimum amount of \$ 1,000,000 per occurrence, and naming City as an additional insured. The insurance required herein shall be primary and shall be attached hereto as "Exhibit A."

6. INDEMNITY AND HOLD HARMLESS

Contractor shall indemnify, defend and hold City, the City Commission of the City of Hobbs, its individual commissioners, its officers, employees and agents, past or present, harmless from any and all causes of action, suits, claims, judgments, losses, costs, expenses, and liens of every kind and nature, including, but not limited to court costs and attorney's fees, arising or alleged to have arisen due to negligence of Contractor, or any employees working under Contractor, while engaged in the performance of this Agreement, or for Contractor's failure to render services, or any breach of this Agreement. Indemnification shall survive the expiration of this Agreement.

City shall not be liable to Contractor, or Contractor's successors, heirs, agents, administrators, or assigns, for any loss, damage, or injury, whether to Contractor's person or property, occurring in connection with Contractor's performance of Contractor's duties according to this Agreement. Contractor shall hold City harmless from all loss, damage, and injury, including court costs and attorney fees, incurred by City in connection with the performance by Contractor of Contractor's duties according to this Agreement.

7. FACILITY AND EQUIPMENT—SAFETY

Contractor shall report any unsafe conditions prior to the commencement of any activity. Commencement of activity by the Contractor constitutes agreement as to the safety of the premises. Contractor is responsible for supervision of all participants so as to conduct the services in a safe and orderly manner. Contractor shall be solely responsible for the safety of any of their employees, affiliates, associates, or subcontractors. City is not required to provide storage for Contractor's equipment or materials.

8. BACKGROUND CHECK

Contractor is subject to a background check prior to providing services. By signing this Agreement, the Contractor is certifying that they have reviewed criminal background histories of each and every employee, assistant and/or agent working for Contractor. Contractor further certifies that no person with a history of sexual or violent offenses is in Contractor's employ in any fashion. Employees, assistants and/or agents who are minors (under 18 years old) shall be supervised by an adult in Contractor's employ at all times.

9. DRUG-FREE WORKPLACE

City seeks to provide a safe and productive work environment that is free from impaired performance caused by the use of alcohol, controlled substances, and/or medications. The Contractor agrees to maintain such an environment.

10. RULES, REGULATIONS, AND CARE

Contractor shall treat all individuals and City employees with respect and will not subject anyone to discrimination or harassment because of the person's race, color, sexual orientation, national origin, age, religion, gender, gender identity, or disability. Contractor shall use all reasonable care so as to not damage, or authorize any other person/entity, to damage the property of City. In the event that any City-owned property, whatsoever, is damaged or destroyed due to the negligence or acts of omissions of the Contractor, or any agent of Contractor, Contractor shall replace or repair the damage at no cost to City. City shall determine the existence of any damage and provide Contractor with an estimate of repair or replacement costs. Damage shall be repaired or replaced by Contractor to the reasonable satisfaction of City within thirty (30) days of receipt of written notification from City. If Contractor fails or refuses to make such repair or replacement, the Contractor shall be liable for the cost, which may be deducted from payments provided for in this Agreement. City reserves the right to immediately cancel the Agreement if the Contractor violates any provision herein.

11. NOTICE

All notices given pursuant to or in connection with this Agreement shall be made in writing and posted by regular mail, postage prepaid, to City, ATTN: Todd Randall, City Hall, 200 E. Broadway Street, Hobbs, NM 88240 and to Contractor at 3831 E Lohman Avenue, Suite 200 Las Cruces, New Mexico 88011 or to such other address as requested in writing by either party. Notice shall be deemed to be received on the fifth day following posting.

12. CONFLICT OF INTEREST AND GOVERNMENTAL CONDUCT ACT

A. Contractor represents and warrants that it presently has no interest and, during the term of this Agreement, shall not acquire any interest, direct or indirect, which would conflict in any manner or degree with the performance or services required under the Agreement.

B. Contractor further represents and warrants that it has complied with, and, during the term of this Agreement, will continue to comply with, and that this Agreement complies with all applicable provisions of the Governmental Conduct Act, Chapter 10, Article 16 NMSA 1978. Without in anyway limiting the generality of the foregoing, the Contractor specifically represents and warrants that:

1) in accordance with NMSA 1978, Section 10-16-4.3, Contractor does not employ, has not employed, and will not employ during the term of this Agreement any City employee while such employee was or is employed by City and participating directly or indirectly in City's contracting process;

2) this Agreement complies with NMSA 1978, Section 10-16-7(B), because (i) Contractor is not a public officer or employee of City; (ii) Contractor is not a member of the family of a public officer or employee of City; (iii) Contractor is not a business in which a public officer or employee or the family of a public officer or employee has a substantial interest; or (iv) if Contractor is a public officer or employee of City, a member of the family of a public officer or employee of City, or a business in which a public officer or employee of City or the family of a public officer or employee of City has a substantial interest, public notice was given as required by NMSA 1978, Section 10-16-7(B), and this Agreement was awarded pursuant to a competitive process;

3) in accordance with NMSA 1978, Section 10-16-8(C), (i) Contractor is not, and has not been represented by, a person who has been a public officer or employee of City within the preceding year and whose official act directly resulted in this Agreement and (ii) Contractor is not, and has not been assisted in any way regarding this transaction by, a former public officer or employee of City whose official act, while in City employment, directly resulted in City making this Agreement;

4) in accordance with NMSA 1978, Section 10-16-13, Contractor has not directly participated in the preparation of specifications, qualifications or evaluation criteria for this Agreement or any procurement related to this Agreement; and

5) in accordance with NMSA 1978, Section 10-16-3 and Section 10-16-13.3, Contractor has not contributed, and during the term of this Agreement shall not contribute, anything of value to a public officer or employee of City.

C. Contractor's representations and warranties in Paragraphs A and B of this Section 12 are material representations of fact upon which City relied when this Agreement was entered into by the parties. Contractor shall provide immediate written notice to City if, at any time during the term of this Agreement, Contractor learns that Contractor's representations and warranties in Paragraphs A and B of this Section 12 were erroneous on the effective date of this Agreement or have become erroneous by reason of new or changed circumstances. If it is later determined that Contractor's representations and warranties in Paragraphs A and B of this Section 12 were erroneous on the effective date of this Agreement or have become erroneous by reason of new or changed circumstances, in addition to other remedies available to City and notwithstanding anything in the Agreement to the contrary, City may immediately terminate the Agreement.

D. All terms defined in the Governmental Conduct Act have the same meaning in Section 12(B).

13. MISCELLANEOUS PROVISIONS

Contractor shall not assign or transfer any interest in this Agreement or assign any claims for money due or to become due under this Agreement without the prior written approval of City.

Contractor shall not subcontract any portion of the services to be performed under this Agreement without the prior written approval of City. No such subcontract shall relieve the primary Contractor from its obligations and liabilities under this Agreement, nor shall any subcontract obligate direct payment from City. In all cases, Contractor is solely responsible for fulfillment of this Agreement. Duly authorized representatives for City shall have the right to direct and inspect the work under this Agreement.

If any part of this Agreement is found to be in violation of the laws or Constitution of New Mexico, only such part thereof shall be thereby invalidated, and all other parts of this Agreement shall remain valid and enforceable.

This Agreement is governed by the laws of the State of New Mexico and will bind and inure to the benefit of City and Contractor, their respective successors and assigns. In the event that Contractor defaults on any term of this Agreement, after reasonable attempts to cure said default, City retains the right to declare this Agreement void. In the event that this Agreement is declared void, neither party shall be obligated to perform further under this Agreement. Jurisdiction and venue relating to any litigation or dispute arising out of this Agreement shall be in the District Court of Lea County, New Mexico, only. Contractor agrees to pay City reasonable costs, including court fees and reasonable attorney's fees, incurred by City in the enforcement of this Agreement, even though City may employ in-house legal counsel.

A party shall be excused from performance under this agreement for any period that the party is directly prevented from performing as a result of an act of God, strike, war, civil disturbance, epidemic, or court order, provided that the party has prudently and promptly acted to take any and all steps that are within the party's control to ensure performance. Subject to this provision, such non-performance shall not be deemed a default or a ground for termination.

In the event that Contractor desires to cancel the scheduled services for any reason, Contractor is responsible for the following:

Contacting City via telephone at 575-397-9237; and
Contacting City via e-mail at trandall@hobbsnm.org.

Any change orders shall be in writing and signed by the parties specifically enumerating the additional work to be performed, change in scope, and/or the cost therein. A party's failure to require strict performance of any provision of this Agreement shall not waive or diminish that party's right thereafter to demand strict compliance with that or any other provision. No waiver by a party of any of its rights under this Agreement shall be effective unless express and in writing, and no effective waiver by a party of any of its rights shall be effective to waive any other rights but the ones delineated in said effective waiver.

If Contractor is other than a natural person, the individual(s) signing this Agreement on behalf of Contractor represents and warrants that they have the legal power and authority to bind Contractor, and that no further action, resolution, or approval from Contractor is necessary to enter into a binding contract.

This Agreement incorporates all of the agreements, covenants and understandings between the parties hereto concerning the subject matter hereof, and all such covenants, agreements and understandings have been merged into this written Agreement. No prior agreement or understanding, oral or otherwise, of the parties or their agents shall be valid or enforceable unless embodied in this Agreement.

The foregoing constitutes the entire Agreement between the parties. This Agreement may only be modified through a written amendment signed by both parties.

[Required Signatures on Next Page]

IN WITNESS WHEREOF, the parties hereto have executed this Agreement the day and year first above written on the first page of this Agreement.

THE CITY OF HOBBS, NEW MEXICO

Department Head Approval:

Account No.: 48-4048-44901-00179

Finance Director:

Finance Director

City Attorney "as to form" Approval:

City Attorney

Contractor Approval:

Maxwell, Dave Digitally signed by Maxwell, Dave
Date: 2023.03.09 11:31:01 -07'00'

Contractor Signature

City Manager Approval:

City Manager

City Clerk Approval:
City Clerk (Professional Service
Contracts over \$75,000)

City Clerk

Mayor Approval:
(Professional Service Contracts over
\$75,000)

Mayor

**Amendment No. 1 – Professional Service Agreement
with Stantec Consulting Services Inc.**

Delete Paragraph 6. – INDEMNITY AND HOLD HARMLESS and replace with the following:

6. INDEMNITY AND HOLD HARMLESS

Contractor shall indemnify and hold the City, the City Commission of the City of Hobbs, its individual commissioners, its officers, and employees, harmless from, but not defend, any and all actions, judgments, losses, costs, expenses, and liens, including, but not limited to court costs and reasonable attorney's fees, to the extent caused by negligence of Contractor, or any employees working under Contractor, while engaged in the performance of this Agreement, or for Contractor's failure to render services, or any breach of this Agreement. Indemnification shall survive the expiration of this Agreement.

City shall not be liable to Contractor, or Contractor's successors, heirs, agents, administrators, or assigns, for any loss, damage, or injury, whether to Contractor's person or property, occurring in connection with Contractor's performance of Contractor's duties according to this Agreement except to the extent such loss, damage, and injury is due to the negligence of City or those for whom City is responsible at law. Contractor shall hold City harmless from all loss, damage, and injury, including court costs and attorney fees, incurred by City in connection with the performance by Contractor of Contractor's duties according to this Agreement.

Any default in the performance of this Agreement caused by any of the following events and without fault or negligence on the part of the defaulting party shall not constitute a breach of contract: labor strikes, riots, war, acts of governmental authorities, unusually severe weather conditions or other natural catastrophe, pandemic or any other cause beyond the reasonable control or contemplation of either party. Nothing herein relieves the City of its obligation to pay the Contractor for services rendered. This provision applies, without limitation, to any impacts caused by, resulting from, or arising out of the COVID-19 pandemic, which was declared a worldwide pandemic by the World Health Organization on March 11, 2020.

Payments to Engineer for Services and Reimbursable Expenses
Basic Services – Standard Hourly Rates (Maximum Not to Exceed Contract)

ARTICLE 1 – OWNER’S RESPONSIBILITIES

1.01 *Compensation For Basic Services – Standard Hourly Rates Method of Payment*

A. Owner shall pay Engineer for Basic Services set forth in Exhibit C, as follows:

1. An amount equal to the cumulative hours charged to the Project by each class of Engineer’s personnel times Standard Hourly Rates for each applicable billing class for all services performed on the Project and Engineer’s Consultants’ charges, if any.
2. The Standard Hourly Rates charged by Engineer constitute full and complete compensation for Engineer’s services, including labor costs, overhead, and profit; the Standard Hourly Rates do not include Engineer’s Consultants’ charges.
3. Engineer’s Standard Hourly Rates are attached to this Exhibit D.
4. The total compensation for services under Paragraph 1.01 is estimated in the Exhibit C per task.
5. Engineer may alter the distribution of compensation between individual phases of the work noted herein to be consistent with services actually rendered, but shall not exceed the total estimated compensation amount unless approved in writing by Owner. See also 1.03.C below.
6. The total estimated compensation for Engineer’s services included in the breakdown by tasks incorporates all labor, overhead, profit, Reimbursable Expenses, and Engineer’s Consultants’ charges.
7. The amounts billed for Engineer’s services Exhibit C will be based on the cumulative hours charged to the Project during the billing period by each class of Engineer’s employees times Standard Hourly Rates for each applicable billing class and Engineer’s Consultants’ charges.

1.02 *Compensation For Reimbursable Expenses*

- A. Not applicable to this contract.

1.03 *Other Provisions Concerning Payment*

- A. Whenever Engineer is entitled to compensation for the charges of Engineer’s Consultants, those charges shall be the amounts billed by Engineer’s Consultants to Engineer with no additional charge.

B. *Estimated Compensation Amounts:*

1. Engineer's estimate of the amounts that will become payable for specified services are only estimates for planning purposes, are not binding on the parties, and are not the minimum or maximum amounts payable to Engineer under the Agreement.
2. When estimated compensation amounts have been stated herein and it subsequently becomes apparent to Engineer that the total compensation amount thus estimated will be exceeded, Engineer shall give Owner written notice thereof, allowing Owner to consider its options, including suspension or termination of Engineer's services for Owner's convenience. Upon notice, Owner and Engineer promptly shall review the matter of services remaining to be performed and compensation for such services. Owner shall either exercise its right to suspend or terminate Engineer's services for Owner's convenience, agree to such compensation exceeding said estimated amount, or agree to a reduction in the remaining services to be rendered by Engineer, so that total compensation for such services will not exceed said estimated amount when such services are completed. If Owner decides not to suspend the Engineer's services during the negotiations and Engineer exceeds the estimated amount before Owner and Engineer have agreed to an increase in the compensation due Engineer or a reduction in the remaining services, then Engineer shall be paid for all services rendered hereunder.

C. To the extent necessary to verify Engineer's charges and upon Owner's timely request, Engineer shall make copies of such records available to Owner at cost.

Reference: College Lane Widening & Realignment Project, RFP No. 538-23, Revised Fee Proposal for Preliminary Engineering

Proposed Fee:

Task	From	To	Amount
200.100 Topographic Surveying	Feb 21	Apr 14	
200.105 Control Survey			\$3,700.00
200.110 Preliminary Right-of-Way Survey			\$21,390.00
200.115 Topographic Survey			\$18,190.00
200.120 Project Management for Surveyor			\$2,297.00
200.125 Utility Reconnaissance			\$4,500.00
Total Topographic Surveying			\$50,077.00
200.200 Geotechnical Study and Pavement Design	Feb 21	Apr 14	
200.205 Geotechnical Engineering Report			\$24,320.00
200.300 Traffic and Safety Study	Feb 21	Apr 14	
200.305 Traffic Counts			\$4,500.00
200.310 Traffic Analysis			\$17,285.00
200.315 Safety Analysis			\$17,228.00
Total Traffic and Safety Study			\$39,013.00
200.400 Preliminary Drainage Report	Feb 21	Apr 14	
200.405 Preliminary Drainage Study			\$41,257.00
200.500 Environmental Study			
200.505 Desktop Environmental Review			\$0.00
200.600 Alignment Study	Apr 17	May 26	
200.605 Develop Criteria for Alignment Study			\$5,425.00
200.610 Develop Alignment			\$21,422.00
200.615 Cost Analysis			\$5,242.00
200.620 Design Analysis Report			\$1,950.00
Total Alignment Study			\$34,039.00
200.700 Public Involvement	Apr 17	May 26	
200.705 Single Stakeholder Meeting			\$3,120.00
200.710 Key Property Owner Interviews			\$1,950.00

Reference: College Lane Widening & Realignment Project, RFP No. 538-23, Revised Fee Proposal for Preliminary Engineering

Total Public Involvement			\$5,070
200.800 Project Management	Feb 21	May 26	
200.805 Meetings with City			\$4,590.00
200.810 Internal Team Meetings			\$7,722.00
200.815 Contract Management			\$10,000.00
200.820 Quality Assurance			\$1,760.00
Total Project Management			\$24,072.00
Sub-Total			\$217,890.00
NMGRT @8.1875%			\$17,839.74
Total			\$235,729.74

Upon completion and acceptance of the preliminary engineering, a fee proposal will be submitted for design services.



CITY OF HOBBS
COMMISSION STAFF SUMMARY FORM
MEETING DATE: MARCH 20, 2023

SUBJECT: APPROVAL OF A C.E.S. CONTRACT BETWEEN THE CITY OF HOBBS AND GUADALUPE MOUNTAIN FENCING, IN THE AMOUNT OF \$253,666.80 FOR THE INSTALLATION OF NEW DECORATIVE/ORNAMENTAL FENCE.

DEPT. OF ORIGIN: PARKS AND OPEN SPACES DEPARTMENT
DATE SUBMITTED: MARCH 10, 2023
SUBMITTED BY: BRYAN WAGNER, PARKS & OPEN SPACES DIRECTOR

SUMMARY:
Guadalupe Mountain Fencing will prepare and install 1,950' of decorative/ornamental fence on east and south side of Prairie Haven Cemetery. The fence will be a 6' Ameristar Montage Plus three rail panels with exposed pickets on top. The project will also include one new 8' double gate. This is the same type of fence that was installed at Prairie Haven Memorial Park Cemetery and Everglade Cemetery. Guadalupe Mountain Fencing provided CES pricing as requested in the project specifications referencing their CES Contract number 2023-03-G1110-ALL. This fence project has been requested and approved by the Cemetery Advisory Board.

Fiscal Impact:
Reviewed By: [Signature]
Finance Department
The total fiscal impact is \$253,666.80, which includes NMGRT. There is \$286,579.97 available for this project in 19-4019-43011.

- Attachments:
1) Quotes from Guadalupe Mountain Fencing, TriWest Fence, and Lone Mountain Contracting, Inc.
2) CES Contract Extension for Guadalupe Mountain Fencing.
3) Quote Pricing Matrix
4) Cemetery Fence Project Specifications
5) Map of fence location.

Legal Review:
Approved As To Form: [Signature]
City Attorney

Recommendation:
Approve the C.E.S. Contract with Guadalupe Mountain Fencing in the amount of \$253,666.80 including NMGRT.

Approved For Submittal By:
[Signature]
Department Director
[Signature]
City Manager



CITY CLERK'S USE ONLY
COMMISSION ACTION TAKEN
Resolution No. _____ Continued To: _____
Ordinance No. _____ Referred To: _____
Approved _____ Denied _____
Other _____ File No. _____

Prairie Haven Cemetery

Fence Project

Location 2

Legend

-  Existing fence removed and install decorative/ornamental fence
-  Perimeter fenceline trees to be removed
-  Prairie Haven Cemetery

E Standford Rd

Prairie Haven Cemetery

Existing fence removed and install decorative/ornamental fence

Perimeter fenceline trees to be removed

Google Earth

700 ft



	Base Bid	Includes NMGRT	Included Pictures of Product
Guadalupe Mountain Fencing	\$253,666.80	yes	yes
TriWest Fence	\$354,740.95	yes	no
Lone Mountain Contracting, Inc.	\$269,173.40	yes	No, cut sheet only



Job Order Contract

Price Proposal Summary - CSI

Date: February 06, 2023
Contract Number: 2023-03-G1110-ALL
Job Order Number: 230206-3.00
Job Order Title: City of Hobbs - Prairie Haven Site 2 Wade Whitehead (2023 Contract)
Contractor: Guadalupe Mountain Fencing
Proposal Value: \$253,666.80
Proposal Name: City of Hobbs - Prairie Haven Site 2 Wade Whitehead (2023 Contract)
Detailed Scope:

Category - 01 - General Requirements:	\$19,145.11
Category - 32 - Exterior Improvements:	\$234,521.69
Proposal Total	\$253,666.80

This proposal total represents the correct total for the proposal. Any discrepancy between line totals, sub-totals and the proposal total is due to rounding of the line totals and sub-totals.

The Percent of NPP on this Proposal: 0.00%

Job Order Contract

Price Proposal Detail - CSI

Date: February 06, 2023
Contract Number: 2023-03-G1110-ALL
Job Order Number: 230206-3.00
Job Order Title: City of Hobbs - Prairie Haven Site 2 Wade Whitehead (2023 Contract)
Contractor: Guadalupe Mountain Fencing
Proposal Value: \$253,666.80
Proposal Name: City of Hobbs - Prairie Haven Site 2 Wade Whitehead (2023 Contract)
Adjustment Factor(s) Used: 1.0000-No Adjustment, 1.4225-1. NWH In Excess of \$60k (State)

Rec#	CSI Number	Mod.	UOM	Description	Line Total																
CSI - 01 - General Requirements																					
1	01 22 16 00 0004		EA	New Mexico Gross Receipts Tax -- Varies by County	\$15,900.61																
				<table border="0"> <tr> <td></td> <td>Quantity</td> <td></td> <td>Unit Price</td> <td></td> <td>Factor</td> <td></td> <td>Total</td> </tr> <tr> <td>Installation</td> <td>15,900.61</td> <td>x</td> <td>\$1.00</td> <td>x</td> <td>1.0000</td> <td>=</td> <td>\$15,900.61</td> </tr> </table>		Quantity		Unit Price		Factor		Total	Installation	15,900.61	x	\$1.00	x	1.0000	=	\$15,900.61	
	Quantity		Unit Price		Factor		Total														
Installation	15,900.61	x	\$1.00	x	1.0000	=	\$15,900.61														
	User Note: Hobbs NMGR @ 6.6675%																				
2	01 22 16 00 0007		EA	Payment And Performance Bond Bonding will be paid to the contractor for eligible costs as directed by Owner. Insert the appropriate quantity to adjust the base cost to the actual Bonding cost. A copy of the receipt, invoice, or proof of payment shall be submitted with the Price Proposal.	\$2,849.20																
				<table border="0"> <tr> <td></td> <td>Quantity</td> <td></td> <td>Unit Price</td> <td></td> <td>Factor</td> <td></td> <td>Total</td> </tr> <tr> <td>Installation</td> <td>2,849.20</td> <td>x</td> <td>\$1.00</td> <td>x</td> <td>1.0000</td> <td>=</td> <td>\$2,849.20</td> </tr> </table>		Quantity		Unit Price		Factor		Total	Installation	2,849.20	x	\$1.00	x	1.0000	=	\$2,849.20	
	Quantity		Unit Price		Factor		Total														
Installation	2,849.20	x	\$1.00	x	1.0000	=	\$2,849.20														
3	01 71 13 00 0002		EA	Equipment Delivery, Pickup, Mobilization And Demobilization Using A Rollback Flatbed Truck Includes loading, tie-down of equipment, delivery of equipment, off loading on site, rigging, dismantling, loading for return and transporting away. For equipment such as trenchers, skid-steer loaders (bobcats), industrial warehouse forklifts, sweepers, scissor platform lifts, telescoping and articulating boom man lifts with up to 40' boom lengths, etc.	\$395.30																
				<table border="0"> <tr> <td></td> <td>Quantity</td> <td></td> <td>Unit Price</td> <td></td> <td>Factor</td> <td></td> <td>Total</td> </tr> <tr> <td>Installation</td> <td>1.00</td> <td>x</td> <td>\$277.89</td> <td>x</td> <td>1.4225</td> <td>=</td> <td>\$395.30</td> </tr> </table>		Quantity		Unit Price		Factor		Total	Installation	1.00	x	\$277.89	x	1.4225	=	\$395.30	
	Quantity		Unit Price		Factor		Total														
Installation	1.00	x	\$277.89	x	1.4225	=	\$395.30														
Subtotal for CSI - 01 - General Requirements:					\$19,145.11																
CSI - 32 - Exterior Improvements																					
4	32 31 13 13 0009		VLF	10" Diameter Hole, Auger By Machine Fence Post Hole In Soil	\$8,079.80																
				<table border="0"> <tr> <td></td> <td>Quantity</td> <td></td> <td>Unit Price</td> <td></td> <td>Factor</td> <td></td> <td>Total</td> </tr> <tr> <td>Installation</td> <td>500.00</td> <td>x</td> <td>\$11.36</td> <td>x</td> <td>1.4225</td> <td>=</td> <td>\$8,079.80</td> </tr> </table>		Quantity		Unit Price		Factor		Total	Installation	500.00	x	\$11.36	x	1.4225	=	\$8,079.80	
	Quantity		Unit Price		Factor		Total														
Installation	500.00	x	\$11.36	x	1.4225	=	\$8,079.80														
5	32 31 13 13 0010		VLF	12" Diameter Hole, Auger By Machine Fence Post Hole In Soil	\$545.81																
				<table border="0"> <tr> <td></td> <td>Quantity</td> <td></td> <td>Unit Price</td> <td></td> <td>Factor</td> <td></td> <td>Total</td> </tr> <tr> <td>Installation</td> <td>30.00</td> <td>x</td> <td>\$12.79</td> <td>x</td> <td>1.4225</td> <td>=</td> <td>\$545.81</td> </tr> </table>		Quantity		Unit Price		Factor		Total	Installation	30.00	x	\$12.79	x	1.4225	=	\$545.81	
	Quantity		Unit Price		Factor		Total														
Installation	30.00	x	\$12.79	x	1.4225	=	\$545.81														
6	32 31 13 13 0026		VLF	10" Diameter, Concrete Fill For Post Hole	\$9,893.49																
				<table border="0"> <tr> <td></td> <td>Quantity</td> <td></td> <td>Unit Price</td> <td></td> <td>Factor</td> <td></td> <td>Total</td> </tr> <tr> <td>Installation</td> <td>500.00</td> <td>x</td> <td>\$13.91</td> <td>x</td> <td>1.4225</td> <td>=</td> <td>\$9,893.49</td> </tr> </table>		Quantity		Unit Price		Factor		Total	Installation	500.00	x	\$13.91	x	1.4225	=	\$9,893.49	
	Quantity		Unit Price		Factor		Total														
Installation	500.00	x	\$13.91	x	1.4225	=	\$9,893.49														
7	32 31 13 13 0027		VLF	12" Diameter, Concrete Fill For Post Hole	\$699.02																
				<table border="0"> <tr> <td></td> <td>Quantity</td> <td></td> <td>Unit Price</td> <td></td> <td>Factor</td> <td></td> <td>Total</td> </tr> <tr> <td>Installation</td> <td>30.00</td> <td>x</td> <td>\$16.38</td> <td>x</td> <td>1.4225</td> <td>=</td> <td>\$699.02</td> </tr> </table>		Quantity		Unit Price		Factor		Total	Installation	30.00	x	\$16.38	x	1.4225	=	\$699.02	
	Quantity		Unit Price		Factor		Total														
Installation	30.00	x	\$16.38	x	1.4225	=	\$699.02														
8	32 31 19 00 0006		LF	6' Wrought Iron Fence, Verticals At >2-1/2" To 3" On Center	\$210,537.11																
				<table border="0"> <tr> <td></td> <td>Quantity</td> <td></td> <td>Unit Price</td> <td></td> <td>Factor</td> <td></td> <td>Total</td> </tr> <tr> <td>Installation</td> <td>1,950.00</td> <td>x</td> <td>\$75.90</td> <td>x</td> <td>1.4225</td> <td>=</td> <td>\$210,537.11</td> </tr> </table>		Quantity		Unit Price		Factor		Total	Installation	1,950.00	x	\$75.90	x	1.4225	=	\$210,537.11	
	Quantity		Unit Price		Factor		Total														
Installation	1,950.00	x	\$75.90	x	1.4225	=	\$210,537.11														
9	32 31 19 00 0006	Mod		For Verticals >2" To 2-1/2" On Center, Add	\$2,030.48																
				<table border="0"> <tr> <td></td> <td>Quantity</td> <td></td> <td>Unit Price</td> <td></td> <td>Factor</td> <td></td> <td>Total</td> </tr> <tr> <td>Installation</td> <td>244.00</td> <td>x</td> <td>\$5.85</td> <td>x</td> <td>1.4225</td> <td>=</td> <td>\$2,030.48</td> </tr> </table>		Quantity		Unit Price		Factor		Total	Installation	244.00	x	\$5.85	x	1.4225	=	\$2,030.48	
	Quantity		Unit Price		Factor		Total														
Installation	244.00	x	\$5.85	x	1.4225	=	\$2,030.48														
	User Note:																				

Price Proposal Detail - CSI Continues..

Job Order Number: 230206-3.00
 Job Order Title: City of Hobbs - Prairie Haven Site 2 Wade Whitehead (2023 Contract)

Rec#	CSI Number	Mod.	UOM	Description	Line Total															
CSI - 32 - Exterior Improvements																				
10	32 31 19 00 0024		LF	6' Double Wrought Iron Gate, Hardware And Associated Trim	\$2,735.98															
			Installation	<table border="0"> <tr> <td>Quantity</td> <td></td> <td>Unit Price</td> <td>Factor</td> <td>Total</td> </tr> <tr> <td>16.00</td> <td>x</td> <td>\$120.21</td> <td>x</td> <td>\$2,735.98</td> </tr> <tr> <td></td> <td></td> <td></td> <td>1.4225 =</td> <td></td> </tr> </table>	Quantity		Unit Price	Factor	Total	16.00	x	\$120.21	x	\$2,735.98				1.4225 =		
Quantity		Unit Price	Factor	Total																
16.00	x	\$120.21	x	\$2,735.98																
			1.4225 =																	
Subtotal for CSI - 32 - Exterior Improvements:					\$234,521.69															
Proposal Total					\$253,666.80															

This proposal total represents the correct total for the proposal. Any discrepancy between line totals, sub-totals and the proposal total is due to rounding of the line totals and sub-totals.

The Percent of NPP on this Proposal: 0.00%

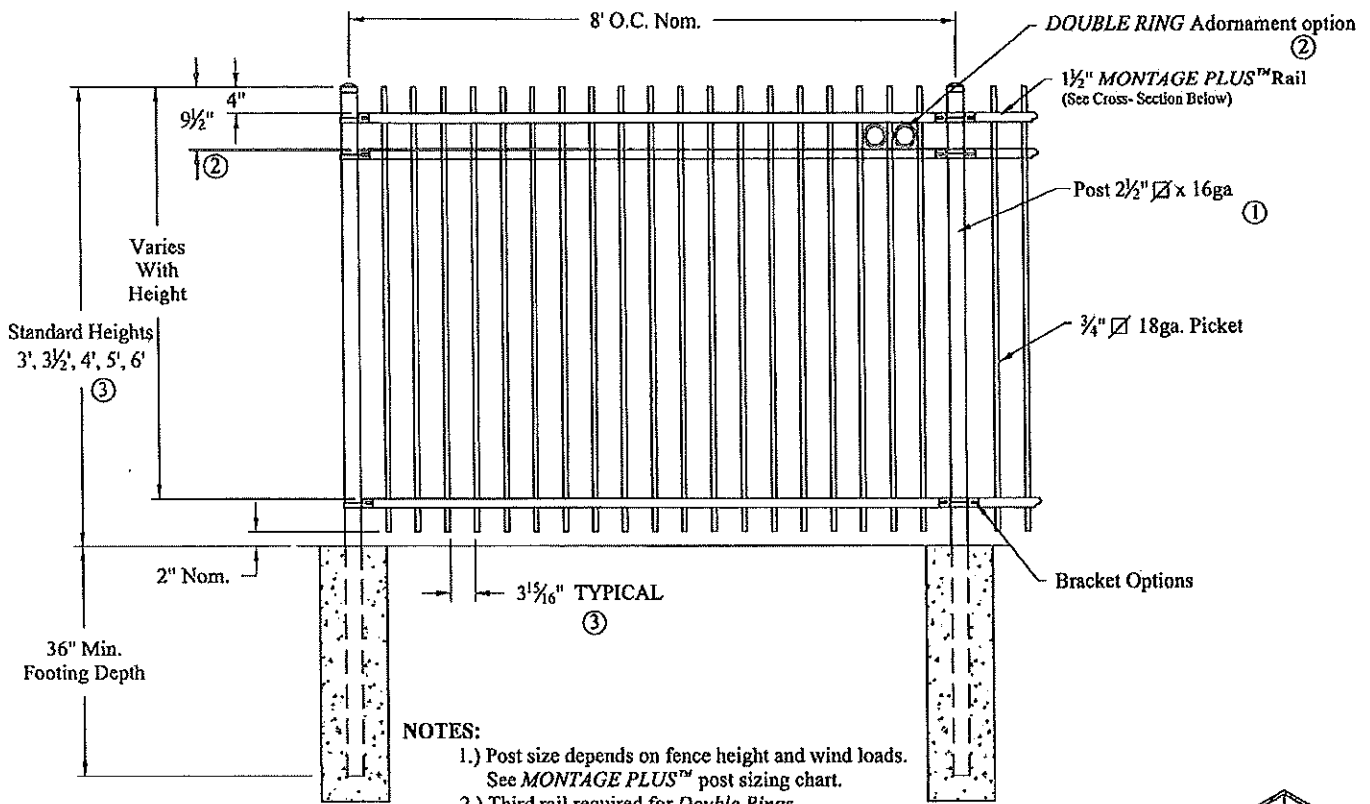

NOTES:

- 1.) Post size depends on fence height and wind loads. See *MONTAGE PLUS™* post sizing chart.
- 2.) Third rail required for *Double Rings*.
- 3.) Available in 3" air space and/or Flush Bottom on most heights.

RAKING DIRECTIONAL ARROW
 Welded panel can be raked 30" over 8' with arrow pointing down grade.

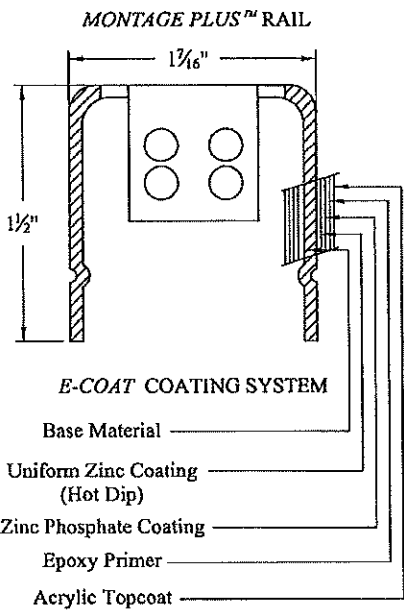

PROFUSION™ WELDING PROCESS
 No exposed welds,
 Good Neighbor profile - Same appearance on both sides

MONTAGE PLUS™ RAIL
 Specially formed high strength architectural shape.

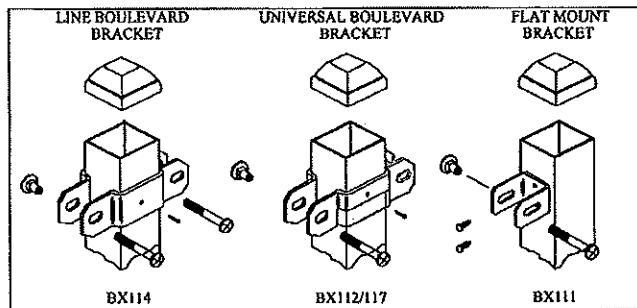

Values shown are nominal and not to be used for installation purposes. See product specification for installation requirements.

IRGISO

COMMERCIAL STRENGTH WELDED STEEL PANEL
PRE-ASSEMBLED

File: **MONTAGE PLUS GENESIS 2/3-RAIL**

DR: CI	SH. 1 of 1	SCALE: DO NOT SCALE
CK: MF	Date 6/28/10	REV: e



AMERISTAR®

1555 N. Mingo
 Tulsa, OK 74116
 1-888-333-3422
 www.ameristarfence.com



MONTAGE PLUS[®]

WELDED ORNAMENTAL STEEL FENCE

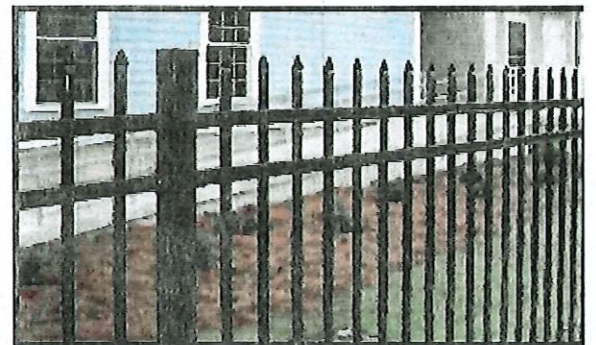

AMERISTARFENCE.COM | 888-333-3422

Experience a safer and more open world

AMERISTAR

ASSA ABLOY



 **CLASSIC™**

- 3', 3½', 4', 5' or 6' Heights
- 2-Rail or 3-Rail Panels
- Extended Picket or Flush Bottom Panels
- 4" Standard or 3" Pet, Pool & Play Picket Air-Space

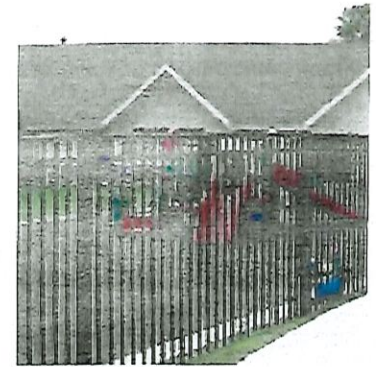
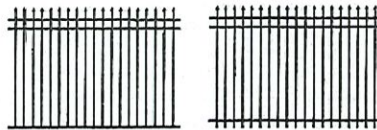

 **MAJESTIC™**

- 3', 3½', 4', 5' or 6' Heights
- 2-Rail or 3-Rail Panels
- Extended Picket or Flush Bottom Panels
- 4" Standard or 3" Pet, Pool & Play Picket Air-Space

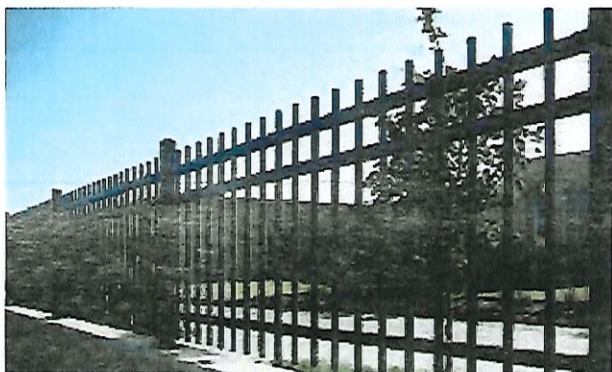

 **GENESIS™**

- 3', 3½', 4', 5' or 6' Heights
- 2-Rail or 3-Rail Panels
- Extended Picket or Flush Bottom Panels
- 4" Standard or 3" Pet, Pool & Play Picket Air-Space

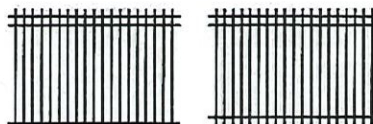

COLOR OPTIO

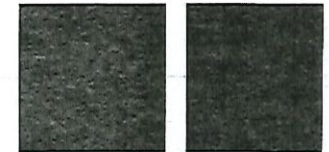

BLACK

BRONZE

MONTAGE PLUS® | Welded Ornamental Steel Fence

PROFUSION WELDING

- ▶ Superior Strength
- ▶ No Visible Rivets or Screws
- ▶ Design Allows Panels to Follow the Grade



Stair-stepping panels



Fully rakeable panels

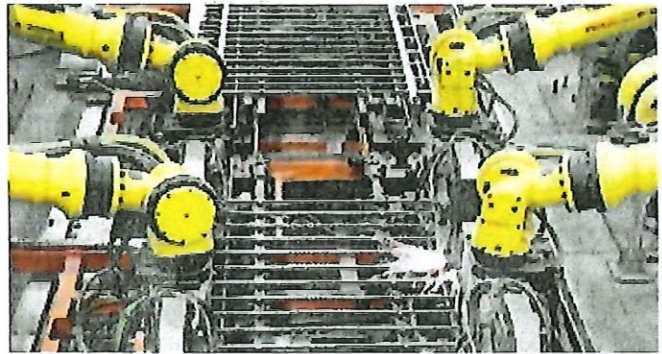

ECOAT FINISH

- ▶ Protection Inside and Out
- ▶ Maintenance-Free Finish
- ▶ Long-Term Durability

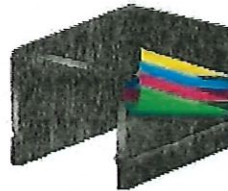

- Acrylic Topcoat
- Epoxy Primer
- Phosphate
- PreGalvanized Steel

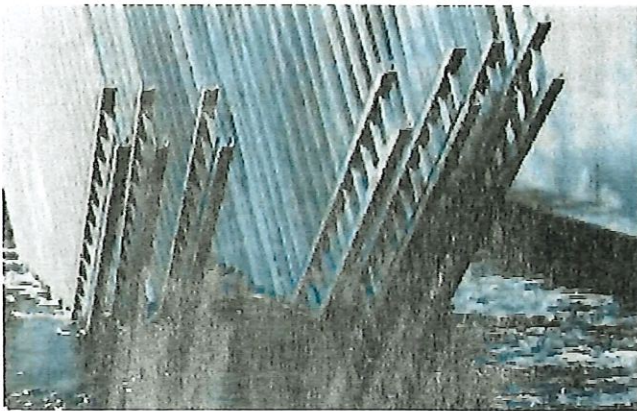

Ameristar's world headquarters, manufacturing & coil processing facilities in Tulsa, Oklahoma, USA.

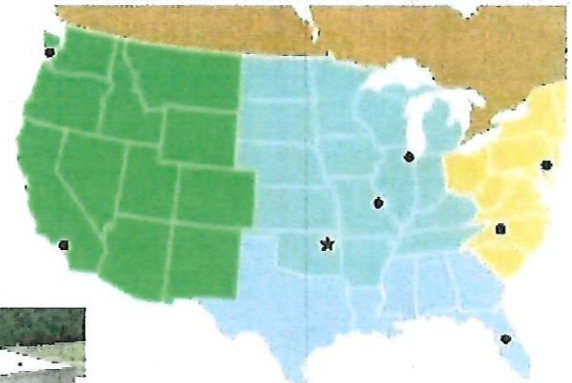

LEGEND

- ★ Ameristar Headquarters
- Sales & Service Centers



Part #98201 Revised 01/2020



AMERISTARFENCE.COM | 888-333-3422

Experience a safer and more open world

AMERISTAR

ASSA ABLOY

AMERISTAR® PERIMETER SECURITY USA INC.
Montage Plus® - Steel Ornamental Fence System – Fusion Welded and Rackable
CONSTRUCTION SPECIFICATION - SECTION 32 31 19

PART 1 - GENERAL

1.01 WORK INCLUDED

The contractor shall provide all labor, materials and appurtenances necessary for installation of the welded ornamental steel fence system defined herein at (specify project site).

1.02 RELATED WORK

Section _____ - Earthwork

Section _____ - Concrete

1.03 SYSTEM DESCRIPTION

The manufacturer shall supply a total fence system of (specify Montage Plus® standard picket space or Montage Plus® Pool, Pet & Play® 3" air space) Welded and Rackable (ATF – All Terrain Flexibility) Ornamental Steel (for standard picket space, specify Classic™, Majestic™, Genesis™, or Warrior™; for 3" air space, specify Classic™, Majestic™, or Genesis™) design. The system shall include all components (i.e., panels, posts, gates and hardware) required.

1.04 QUALITY ASSURANCE

The contractor shall provide laborers and supervisors who are thoroughly familiar with the type of construction involved and materials and techniques specified.

1.05 REFERENCES

- ASTM A653/A653M - Standard Specification for Steel Sheet, Zinc-Coated (Galvanized) or Zinc-Iron Alloy Coated (Galvannealed) by the Hot-Dip Process.
- ASTM B117 - Practice for Operating Salt-Spray (Fog) Apparatus.
- ASTM D523 - Test Method for Specular Gloss
- ASTM D714 - Test Method for Evaluating Degree of Blistering in Paint.
- ASTM D822 - Practice for Conducting Tests on Paint and Related Coatings and Materials using Filtered Open-Flame Carbon-Arc Light and Water Exposure Apparatus.
- ASTM D1654 - Test Method for Evaluation of Painted or Coated Specimens Subjected to Corrosive Environments.
- ASTM D2244 - Test Method for Calculation of Color Differences from Instrumentally Measured Color Coordinates.
- ASTM D2794 - Test Method for Resistance of Organic Coatings to the Effects of Rapid Deformation (Impact).
- ASTM D3359 - Test Method for Measuring Adhesion by Tape Test.
- ASTM F2408 – Ornamental Fences Employing Galvanized Steel Tubular Pickets.

1.06 SUBMITTAL

The manufacturer's literature shall be submitted prior to installation.

1.07 PRODUCT HANDLING AND STORAGE

Upon receipt at the job site, all materials shall be checked to ensure that no damage occurred during shipping or handling. Materials shall be stored in such a manner to ensure proper ventilation and drainage, and to protect against damage, weather, vandalism and theft.

1.08 PRODUCT WARRANTY

A. All structural fence components (i.e. rails, pickets, and posts) shall be warranted within specified limitations, by the manufacturer for a period of 20 years from date of original purchase. Warranty shall cover any defects in material finish, including cracking, peeling, chipping, blistering or corroding.

B. Reimbursement for labor necessary to restore or replace components that have been found to be defective under the terms of manufactures warranty shall be guaranteed for five (5) years from date of original purchase.

PART 2 - MATERIALS

2.01 MANUFACTURER

The fence system shall conform to (specify Montage Plus standard picket space or Montage Plus Pool, Pet & Play 3" air space) Welded and Rackable (ATF – All Terrain Flexibility) Ornamental Steel, (for standard picket space, specify Classic, Majestic, Genesis or Warrior; for 3" air space, specify Classic, Majestic, or Genesis) design, (specify extended picket or flush) bottom rail treatment, (specify 2-Rail, 3-Rail or 3-Rail with Double Rings) style manufactured by Ameristar Fence Products, Inc., in Tulsa, Oklahoma.

2.02 MATERIAL

A. Steel material for fence panels and posts shall conform to the requirements of ASTM A653/A653M, with a minimum yield strength of 45,000 psi (310 MPa) and a minimum zinc (hot-dip galvanized) coating weight of 0.60 oz/ft² (184 g/m²), Coating Designation G-60.

B. Material for pickets shall be 3/4" square x 18 Ga. tubing. The rails shall be steel channel, 1.5" x 1.4375" x 14 Ga. Picket holes in the rail shall be spaced (specify 4.675" o.c. for standard picket space or 3.500" o.c. for 3" air space). Fence posts and gate posts shall meet the minimum size requirements of Table 1.

2.03 FABRICATION

A. Pickets, rails and posts shall be pre-cut to specified lengths. Rails shall be pre-punched to accept pickets.

B. Pickets shall be inserted into the pre-punched holes in the rails and shall be aligned to standard spacing using a specially calibrated alignment fixture. The aligned pickets and rails shall be joined at each picket-to-rail intersection by Ameristar's proprietary fusion welding process, thus completing the rigid panel assembly (Note: The process produces a virtually seamless, spatter-free good-neighbor appearance, equally attractive from either side of the panel).

C. The manufactured panels and posts shall be subjected to an inline electrode position coating (E-Coat) process consisting of a multi-stage pretreatment/wash, followed by a duplex application of an epoxy primer and an acrylic topcoat. The minimum cumulative coating thickness of epoxy and acrylic shall be 2 mils (0.058 mm). The color shall be (specify Black or Bronze). The coated panels and posts shall be capable of meeting the performance requirements for each quality characteristic shown in Table 2 (Note: The requirements in Table 2 meet or exceed the coating performance criteria of ASTM F2408).

D. The manufactured fence system shall be capable of meeting the vertical load, horizontal load, and infill performance requirements for Commercial weight fences under ASTM F2408.

E. Gates with an out to out leaf dimension less than and including 72 inches shall be fabricated using Montage Plus ornamental panel material and 1-3/4" sq. x 14ga. gate ends. Gate leaves greater than 72 inches shall be fabricated using ForeRunner rails, 17 gauge pickets, intermediate uprights, gussets and 1-3/4" sq. x 14ga. gate ends. All rail and upright intersections shall be joined by welding. All picket and rail intersections shall also be joined by welding.

PART 3 - EXECUTION

3.01 PREPARATION

All new installation shall be laid out by the contractor in accordance with the construction plans.

3.02 INSTALLATION

Fence post shall be spaced according to Table 3, plus or minus 1/4". For installations that must be raked to follow sloping grades, the post spacing dimension must be measured along the grade. Fence panels shall be attached to posts with brackets supplied by the manufacturer. Posts shall be set in concrete footers having a minimum depth of 36" (Note: In some cases, local restrictions of freezing weather conditions may require a greater depth). The "Earthwork" and "Concrete" sections of this specification shall govern material requirements for the concrete footer. Posts setting by other methods such as plated posts or grouted core-drilled footers are permissible only if shown by engineering analysis to be sufficient in strength for the intended application.

3.03 FENCE INSTALLATION MAINTENANCE

When cutting/drilling rails or posts adhere to the following steps to seal the exposed steel surfaces; 1) Remove all metal shavings from cut area. 2) Apply zinc-rich primer to thoroughly cover cut edge and/or drilled hole; let dry. 3) Apply 2 coats of custom finish paint matching fence color. Failure to seal exposed surfaces per steps 1-3 above will negate warranty. Ameristar spray cans or paint pens shall be used to prime and finish exposed surfaces; it is recommended that paint pens be used to prevent overspray. Use of non-Ameristar parts or components will negate the manufactures' warranty.

3.04 GATE INSTALLATION

Gate posts shall be spaced according to the manufacturers' gate drawings, dependent on standard out-to-out gate leaf dimensions and gate hardware selected. Type and quantity of gate hinges shall be based on the application; weight, height, and number of gate cycles. The manufacturers' gate drawings shall identify the necessary gate hardware required for the application. Gate hardware shall be provided by the manufacture of the gate and shall be installed per manufacturer's recommendations.

3.05 CLEANING

The contractor shall clean the jobsite of excess materials; post-hole excavations shall be scattered uniformly away from posts.

Table 1 – Minimum Sizes for Montage Plus Posts

Fence Posts		Panel Height	
2-1/2" x 16 Ga.		Up to & Including 6' Height	
Gate Leaf	Gate Height		
	Up to & Including 4'	Over 4' Up to & Including 6'	
Up to 4'	2-1/2" x 14 Ga.	3" x 12 Ga.	
4'1" to 6'	3" x 12 Ga.	3" x 12 Ga.	
6'1" to 8'	3" x 12 Ga.	4" x 12 Ga.	

Table 2 – Coating Performance Requirements

Quality Characteristics	ASTM Test Method	Performance Requirements
Adhesion	D3359 – Method B	Adhesion (Retention of Coating) over 90% of test area (Tape and knife test).
Corrosion Resistance	B117, D714 & D1654	Corrosion Resistance over 1,500 hours (Scribed per D1654; failure mode is accumulation of 1/8" coating loss from scribe or medium #8 blisters).
Impact Resistance	D2794	Impact Resistance over 60 inch lb. (Forward impact using 0.625" ball).
Weathering Resistance	D822 D2244, D523 (60° Method)	Weathering Resistance over 1,000 hours (Failure mode is 60% loss of gloss or color variance of more than 3 delta-E color units).

Table 3 – Montage Plus – Post Spacing By Bracket Type

Span	For CLASSIC, GENESIS, MAJESTIC, & WARRIOR 8' Nominal (91.95" Rail)					
Post Size	2-1/2"	2-1/2"	2-1/2"	3"	2-1/2"	3"
Bracket Type	Montage Plus Universal (BB112)	Montage Plus Line Blvd. (BB114)	Montage Plus Flat Mount (BB111)		Montage Plus Swivel (BB113)*	
Post Settings ± 1/4" O.C.	95"	95"	95"	95-1/2"	*95"	*95-1/2"

*Note: When using BB113 swivel brackets on either or both ends of a panel installation, care must be taken to ensure the spacing between post and adjoining pickets meets applicable codes. This will require trimming one or both ends of the panel.

MONTAGE® SWING GATES | LIMITED WARRANTY

WELDED ORNAMENTAL GATES

Revised 06/2019

Warranty includes swing gates for the entire Montage product line i.e. Montage, Montage Plus, Montage Commercial, Montage Industrial & Montage II.

Montage® Welded Swing Gates by Ameristar® are manufactured from the highest quality materials by skilled craftsmen to meet the highest standards of workmanship in the industry.

Ameristar Perimeter Security hereby certifies that its gates are free from defects in material or workmanship and all gate components and hardware are guaranteed against such defects for a one (1) year period from the original date of purchase. (Note: Accidental damages, defects resulting from improper installation techniques, and damage from abuse or vandalism are not included herein).

Additionally, the coated surface on Montage Welded Swing Gates, including all gate components and hardware, is guaranteed under normal and proper usage, against cracking, peeling, chipping, blistering or corroding for a period of one (1) year from the original purchase date. Normal and proper usage does not include physical damage, abrasion or exposure to salty environments to the protective coating.

Should any Montage Welded Swing Gate or gate component manufactured by Ameristar fail in accordance with any of the above conditions, Ameristar warrants to the original purchaser their redemption through replacement or renewal. The decision as to which method of redemption is allowed is solely at the discretion of Ameristar. Notice of failure under the conditions of this warranty shall be sent to Ameristar or its authorized representative, in writing, together with proof of purchase and shall specify the nature of the defect and when it was first observed. Should the gate be improperly assembled or installed, Ameristar shall not be responsible for guaranteed performance or appearance of the material. Neither does this guarantee apply when failure or damage is due to improper use or application, abuse or misuse, vandalism or acts of God. Ameristar reserves the right to inspect the material to determine validity of the claim.

Upon validation of the claim by Ameristar or its authorized representative, redemption by replacement or renewal shall be made by Ameristar. Reimbursement for the costs of removal and installation of materials are not included in the guarantee, nor will Ameristar provide those services.

The above constitutes the complete warranty by the manufacturer. No other agreement, written or implied, is valid. Ameristar does not authorize any other person or agent to make any other express warranties. Ameristar neither assumes, nor authorizes any other person or agent to assume, any other liability in connection with Montage Welded Swing Gates. Some jurisdictions do not allow limitations on how long an implied warranty lasts, nor do they allow an exclusion or limitation of incidental or consequential damages; therefore, the limitations and exclusions noted herein may not apply.



AMERISTARFENCE.COM | 888-333-3422

ASSA ABLOY, the global leader in door opening solutions

AMERISTAR®

ASSA ABLOY

MONTAGE PLUS® | WARRANTY WELDED ORNAMENTAL FENCE

Ameristar's Montage Plus® welded ornamental fences are manufactured from the highest quality materials by skilled craftsmen to meet the highest standards of workmanship in the industry. Galvanized steel framework is subjected to a multi-stage pretreatment/wash (with zinc phosphate), followed by a duplex cathodic electro-coat system consisting of an epoxy primer, which significantly increases corrosion protection, and an acrylic liquid topcoat, which provides the protection necessary to withstand adverse weathering effects.

The electro-coated surface on all Montage Plus welded ornamental panels and posts are guaranteed under normal and intended usage, against cracking, peeling, chipping, blistering or corroding commencing with the original purchase date and extending according to the applications defined in the table below. Normal and intended usage does not include physical damage, abrasion, or heavy salt spray exposure to the protective coating.

The following acts and/or omissions will void the subject warranty:

- Damage to the product caused by the property owner by use of landscape, gardening equipment, chemicals that may cause damage, and/or water sprinklers with high mineral content;
- Damage caused by adhesion of chicken wire, chain link mesh, welded wire, or other similar substance to the product;
- Damage caused by allowing plant life of any sort to grow directly upon or in contact with any portion of the product or sap from trees;
- Any alteration to the product itself by the property owner including any on-site cutting or welding; and/or, failure to follow any and all maintenance instructions provided by Ameristar® at the time of sale to the original purchaser even if these instructions are not forwarded to the ultimate claimant under this warranty.
- When cutting Montage Plus immediately seal the exposed surfaces by 1) Removing all metal shavings from the cut area 2) Applying zinc-rich primer to thoroughly cover cut edge and drilled hole and, after letting dry, 3) Applying two (2) coats of custom finish spray paint matching fence color. Failure to seal exposed surfaces per steps 1-3 above will negate warranty.
- If contractor uses non-Ameristar parts/components, this will negate the warranty.

Ameristar Montage Plus welded ornamental fences are also guaranteed for the same period of time against defects in workmanship or materials. Should any Montage Plus welded ornamental panel or post manufactured by Ameristar fail in accordance with any of the above conditions, Ameristar warrants to the original purchaser their redemption through replacement, renewal or issuance of a pro-rated credit. The choice of redemption method is solely at the discretion of Ameristar. If the pro-rated alternative is chosen, the amount will be based on the original cost of materials at the date of purchase multiplied by the appropriate time and exposure factor from the table below:

<u>Application</u>	<u>Length of Warranty</u>
Fence Installations 0 to 1 Mile from Salt Water Coast Line	5 Years
Fence Installations 1 Mile to 10 Miles from Salt Water Coast Line	10 Years
Fence Installations Over 10 Miles from Salt Water Coast Line	20 Years

Note: Regardless of location and years in service, evidence of historical salt spray exposure shall be considered as grounds to void any warranty obligations.

Notice of failure under the conditions of this warranty shall be sent to Ameristar or its authorized representative, in writing, together with proof of purchase and shall specify the nature of the defect and when it was first observed as well as photographs of current site conditions. Should the fence be improperly installed, Ameristar shall not be responsible for guaranteed performance or appearance of the material. Neither does this guarantee apply when failure or damage is due to improper use or application, abuse or misuse, salt spray exposure (see Table and Note above), vandalism, or acts of God. Ameristar reserves the right to inspect the material to determine validity of the claim.

Upon acceptance of the claim by Ameristar or its authorized representative, redemption by replacement, renewal or issuance of a pro-rated credit shall be made by Ameristar. Reimbursement for labor necessary to restore and/or replace components that have been found defective under the terms of this warranty is guaranteed to the original purchaser for a period of five (5) years from the original purchase date. Ameristar reserves the right to select the qualified company or individual to perform the labor to repair or replace the components that are deemed to be defective under the terms of this warranty.

The above constitutes the complete warranty by the manufacturer. No other agreement, written or implied, is valid. Ameristar Fence Products does not authorize any other person or agent to make any other express warranties. Ameristar neither assumes nor authorizes any other person or agent to assume any other liability in connection with the Montage Plus welded ornamental fence system.



AMERISTAR®
FENCE PRODUCTS

1555 N. MINGO RD., TULSA, OK 74116
WWW.AMERISTARFENCE.COM

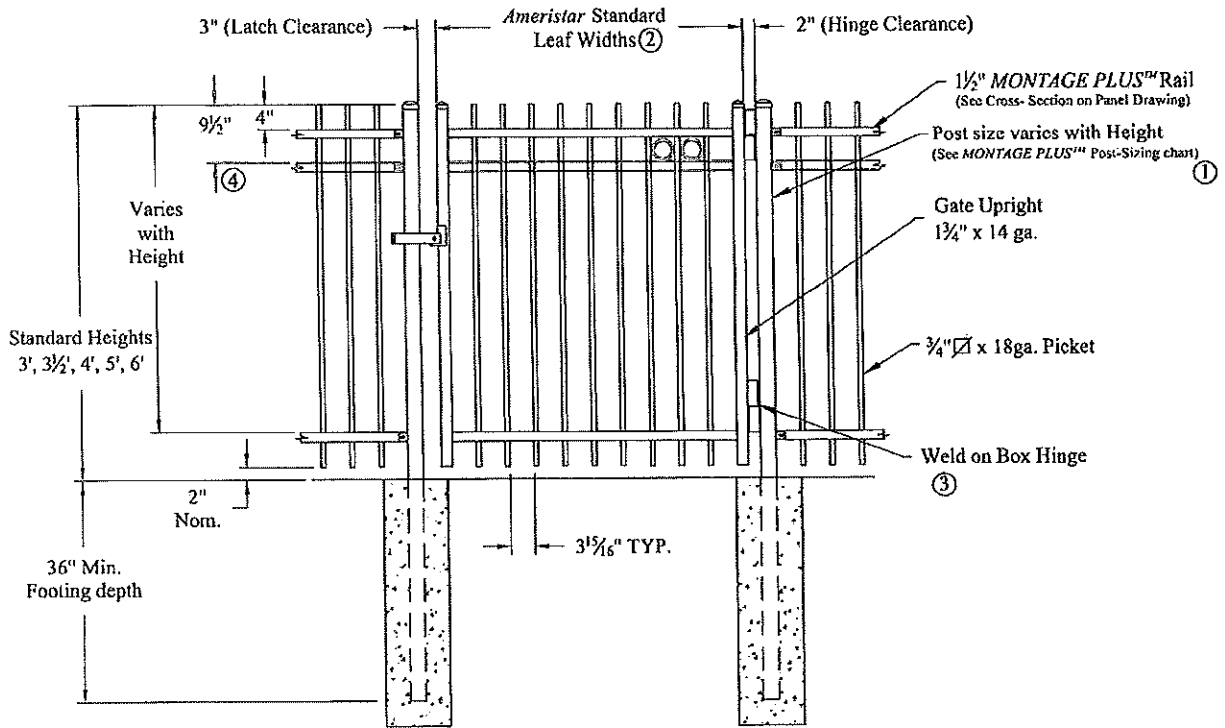

NOTES: *Single gate Arrangement*

- 1.) Post size depends on fence height, weight and wind loads. See *MONTAGE PLUS™* post sizing chart.
- 2.) See *Ameristar* gate table for standard out to outs. Custom gate openings available for special out to out/leaf widths.
- 3.) Additional styles of gate hardware are available on request. This could change the Latch & Hinge Clearance.
- 4.) Third rail required for *Double Rings*.

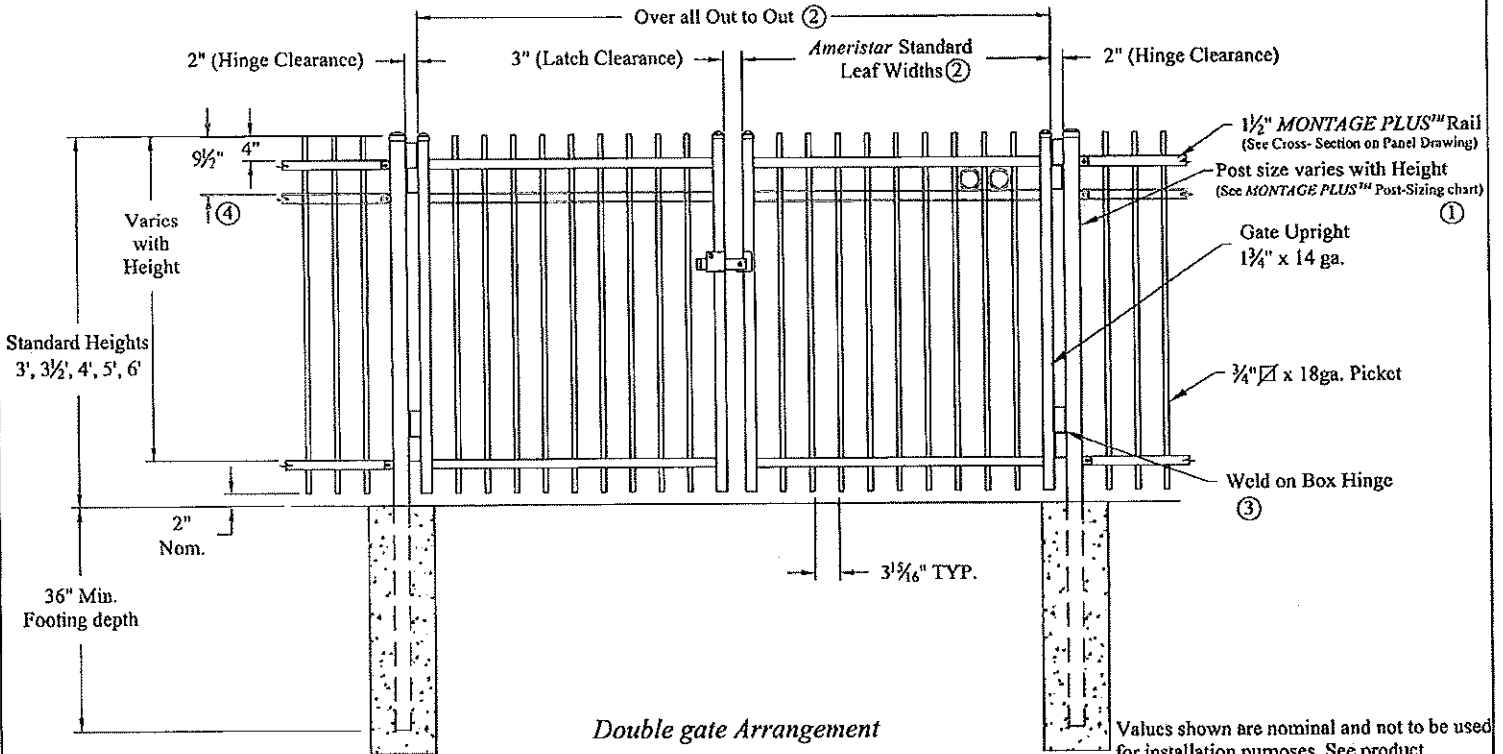

Double gate Arrangement

Values shown are nominal and not to be used for installation purposes. See product specification for installation requirements.

IRGISOG

COMMERCIAL STRENGTH WELDED STEEL GATE

Title: **MONTAGE PLUS GENESIS 2/3-RAIL SGL & DBL GATE**

DR: CI	SH. 1 of 1	SCALE: DO NOT SCALE
CK: ME	Date 6/28/10	REV: e



AMERISTAR®

1555 N. Mingo
Tulsa, OK 74116
1-888-333-3422
www.ameristarfence.com



125 Bosque Farms Blvd, Bosque Farms NM 87068

CONTACT **Steve Kerns** Per New Scope
 OFFICE (505) 869-2996
 DIRECT (505) 730-1737

FED EIN # 88-0117505

NM CID License # 18995 CES#19-028B-C102-All

Classifications: GB02, GB98, GF01, GF04, GF05, GF07, GF08, GF09, GS21, GS29, MM01

NM RES. Preference # L2054064944

NM DOL # 1946020110712

GAGE/SAM # ODYS2

DUNS # 066237454

JOB NAME: Prairie Haven Cemetery Fence Project R1

DATE 01/16/2023

LOCATION: East Stanolind Rd, Hobbs

THIS PROJECT WAS BID USING WAGE DECISION #

SUBMITTED TO: City Of Hobbs Parks

NMA

ATTENTION: City Of Hobbs Parks

BID ITEM NO.	ESTIMATED DURATION	DESCRIPTION	UNIT	Est. Qty.	BID UNIT PRICE	TOTAL PRICE
--------------	--------------------	-------------	------	-----------	----------------	-------------

BASE BID

1		Remove and haul away existing fence east and west side. - - LEAVING south fence	FT	2,628.0	\$2.50	\$ 6,570.00
2		Remove and haul away existing perimeter trees on East, South and West side	DELETED			\$ -
3	17 Cal Dys	Install 6' h New Montage Plus - Genesis Steel Decorative/Ornamental Fence on East and South side - - Three rail panels, Exposed 3/4" pickets top and bottom, Quad Flare and Double Rings. Including Footing as Req'd	FT	1,944.0	\$114.00	\$ 221,616.00
4	1 Cal Dys	Double standard/flat design 6 h x 8' ea Swing Gate for Service Access on south boundary, Including Footing as Req'd	EA	1.0	\$9,500.00	\$ 9,500.00
5	1 Cal Dys	Four additional 6' h x 8' L fence panels	EA	4.0	\$600.00	\$ 2,400.00
6		MOBILIZATION	LS	1.0	\$25,895.00	\$ 25,895.00

BASE BID SUBTOTAL:	\$265,981.00
CES FEE	@ 1.1250% = \$2,992.29
BASE BID NMGR:	@ 6.6875% = \$200.11
Fee & Tax:	\$3,192.40
BASE BID TOTAL =	\$269,173.40



125 Bosque Farms Blvd, Bosque Farms NM 87068

CONTACT **Steve Kerns** Per New Scope
 OFFICE (505) 869-2996
 DIRECT (505) 730-1737

FED EIN # 88-0117505

NM CID License # 18995

Classifications: GB02, GB98, GF01, GF04, GF05, GF07, GF08, GF09, GS21, GS29, MM01

NM RES. Preference # L2054064944

NM DOL # 1946020110712

GAGE/SAM # ODYS2

DUNS # 066237454

JOB NAME: Prairie Haven Cemetery Fence Project R1

DATE 01/16/2023

LOCATION: East Stanolind Rd, Hobbs

THIS PROJECT WAS BID USING WAGE DECISION #
NMA

SUBMITTED TO: City Of Hobbs Parks

ATTENTION: City Of Hobbs Parks

BID ITEM NO.	ESTIMATED DURATION	DESCRIPTION	UNIT	Est. Qty.	BID UNIT PRICE	TOTAL PRICE
--------------	--------------------	-------------	------	-----------	----------------	-------------

ADD ALTERNATE FOR WEST SIDE FENCE

7		Install New Steel Decorative/Ornamental Fence on west side - - Three rail panels, Exposed 3/4" pickets top and bottom, Quad Flare and Double Rings, Including Footing as Req'd	FT	1,300	\$126.00	\$ 163,800.00
---	--	--	----	-------	----------	---------------

ALT BIDS SUBTOTAL:	\$163,800.00
ALT BIDS BOND FEE:	@ 1.1250% = \$1,842.75
ALT BIDS NMGR:	@ 6.6875% = \$123.23
Fee & Tax:	\$1,965.98
ALT BIDS TOTAL =	\$165,765.98

ASSUMPTIONS/BID QUALIFICATIONS:

We have bid this project with 1 Equipment Mob in and out. Any Others MAY be billed at the rate of: **\$14,721.00**

Due to our suppliers pricing instability and continued increases, material pricing can only be held & guaranteed for 14 days from date of this proposal. After that any material pricing changes may be passed on and accounted for via a change to the contract.

All materials provided by this Vendor/Subcontractor are currently subject to supply chain disruption and or unavailability at the source from supply chain disruption or labor availability. The Unavailability of the material is not an event either the fault of the Vendor/Subcontractor or the Project Owner or Owners Construction Team. Vendor/Subcontractor will advise of all known disruption of material availability for this project that may impact the Schedule. In no event is material disruption a material or minor Breach of the Purchase Order/Subcontract. Owner waives all claims against the Vendor/Subcontractor for material supply or availability disruption.

We recognizes the historic price movement in materials as well as suppliers limit to hold quoted price for any length of time. We feel the material prices for our industry will stabilize and begin to decline. Once material we have included in this proposal declines at least 6 percent we would like to pass the savings to you at that time.

ESTIMATED DURATION is provided only as an initial guide for our work's duration. Actual durations may be faster or slower. A preliminary project schedule will be provided to indicate our work's durations at the beginning of the project.

A UOM of LSU indicates the associated bid item is based on the QTY indicated and the actual installed amount will be subject either an increase or a decrease of the billing total when the installed amount differs by more than 15%



125 Bosque Farms Blvd, Bosque Farms NM 87068

CONTACT Steve Kerns Per New Scope
 OFFICE (505) 869-2996
 DIRECT (505) 730-1737

FED EIN # 88-0117505

NM CID License # 18995

Classifications: GB02, GB98, GF01, GF04, GF05, GF07, GF08, GF09, GS21, GS29, MM01

NM RES. Preference # L2054064944

NM DOL # 1946020110712

GAGE/SAM # ODYS2

DUNS # 066237454

JOB NAME: Prairie Haven Cemetery Fence Project R1

LOCATION: East Stanolind Rd, Hobbs

SUBMITTED TO: City Of Hobbs Parks

ATTENTION: City Of Hobbs Parks

DATE 01/16/2023

THIS PROJECT WAS BID USING WAGE DECISION # NMA

BID ITEM NO.	ESTIMATED DURATION	DESCRIPTION	UNIT	Est. Qty.	BID UNIT PRICE	TOTAL PRICE
TOTAL BID SUBTOTAL:						\$434,939.38
TOTAL BID BOND FEE:						@ 1.6100% = \$7,002.52
TOTAL BID NMGR:						@ 6.6875% = \$468.29
Bond & Tax:						\$7,002.52
TOTAL BID TOTAL =						\$441,941.90

ACKNOWLEDGED ADDENDUM:

NONE

We have bid this project per the documents provided up to this bid date. We have provided a summary of our work as a means to verify a general bid completeness. It may not represent the all portions, parts, extent or limit of our work. Please review the scope and exclusions below. Please call for any clarifications.

We have to exclude the following work or items for this project:

Bond Fees	NPDES	Temp Fencing	Design Delegation
NM Gross Receipt Tax	SWPPP	Temporary Utilities	Pedestrian Life-Safe/Pathways
Permit Fees	Builders Risk	All Electrical	RIPRAP
Engineering	Special Insurance	Dewatering	X-Ray of Any Kind
Density Testing Fees	Survey/Staking	Soils Import/Export	Natural/LP Gas Systems
City Engineering Fees	Dust Control/Protection	Native Seeding	Electronic Signatures
Utility Expansion Fees	Landscape Remove/Replace	Rock Excavation	Traffic Control or Flagmen
Testing/Sampling/Lab Analysis	Irrigation System: Remove/Replace	Protection of Installed Construi	Asphalt Remove/Replace
DocuSign Contracts	Vibration/Noise Control/Monitoring	Grade Work Not Associated W/	Concrete Remove/Replace

ITEMS/QUANTITIES NOT LISTED OR CLEARLY SHOWN ON BID PLANS AND PER THIS PROPOSAL.

NM DEPT OF LABOR REGISTRATION NUMBER: 1946020110712
 NM RES. Preference #: L2054064944

NOTE: With the exception of materials, this proposal may be withdrawn if not accepted within 90 days of original date quoted.

THIS DOCUMENT WILL BE ATTACHED AND BOUND TO ANY CONTRACT ISSUED TO (), FOR THE PROJECT INDICATED ABOVE.

Receipt of Payment will be made as follows:

Upon completion of the work or on a monthly schedule, whichever is sooner.

As a subcontractor, "COMPANY" will be due payment per

the contract issued to the project indicated above.

FINANCE CHARGES of 1.5% per month (18% per annum) service charge will be invoiced on past due accounts

Acceptance proposal --- the above prices, specifications and conditions are satisfactory and are hereby accepted to do the work as specified.

Payment to be made as outlined above.

Please Call with Questions
 Steve Davis
 CELL: (505) 948-0025
 DATA: SD@Reagan.com

Accepted By: _____
 Date of Acceptance: _____

Respectfully: Steve Davis

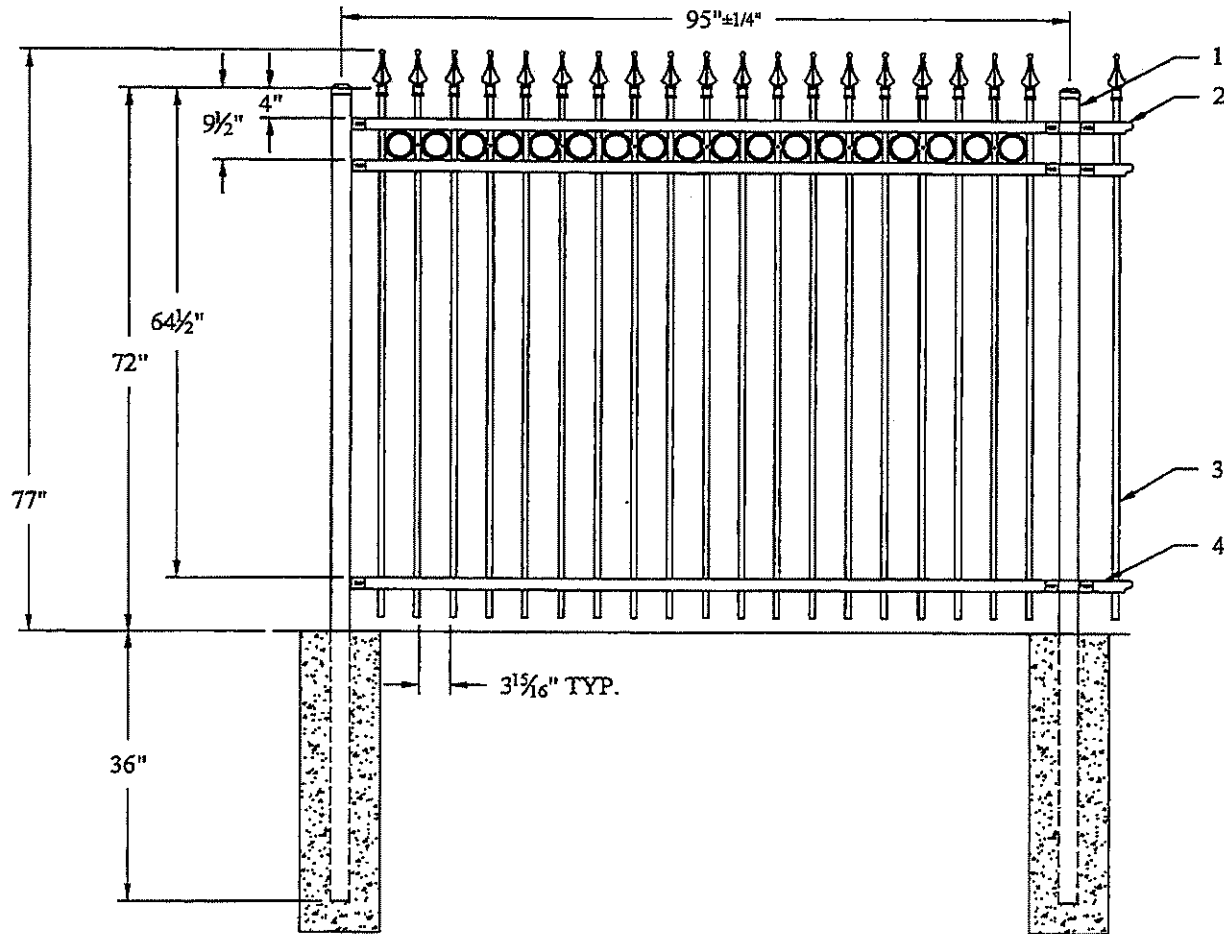

#	QTY.	DESCRIPTION
1	2	5/8" Sq. POST
2	3	1/2" x 1 1/2" RIBBED CHANNEL RAIL
3	19	3/8" Sq. PICKET
4	6	BRACKETS

SPECIAL INSTALL
Rings & Finials

PROPRIETARY INFORMATION					AMERISTAR®		
<small>This drawing is the proprietary property of AMERISTAR, Tulsa, OK and must not be duplicated or used in whole or in part for the making of drawings, prints or parts to the detriment of or benefit of any owner. In accepting this drawing, the recipient agrees to keep the information contained confidential.</small>					<small>1555 N. Mayo Tulsa, OK 74116 1-888-333-1422 www.ameristarfence.com</small>		
<small>REV</small> BY CKD DATE DESCRIPTION					TITLE: MONTAGE PLUS GENESIS 3R EXT 6T 8' PANEL W/RINGS		
<small>b</small> JAS CI 1-19-10 GC Spacing was 5/8" @ 1/2"					DATE: 04/16/09	SCALE: DNS	SHEET: 1/1
					DRN BY: JAZ	CHK BY: JM	REV: a
					DRAWING NO: 1RGX370		



TriWest Fence LLC
 110 Denny Rd
 Bernalillo, NM 87004
 Telephone (505) 264-1780
 Fax (505) 867-6098

Contractor's License: GB98 - 378216
 Workforce Solution Reg # 02899220130531

TO: City of Hobbs
200 E. Broadway
Hobbs, NBM 88240

Project: Prairie Haven Cemetery
 Project Address: 2100 E. Stanolind Rd.
Hobbs, NM

Date	Billing Address Same	
01/11/23		
Customer Account #	<u>wwhitehead@hobbsnm.org</u>	
Phone Number	City / State / Zip Code	
575-397-9289		
Fax Number	Mobile / Job Site Phone Numbers	
	575-602-8608	
Manager Approval	Admin Approval	Quote#

SCOPE OF WORK: TriWest Fence LLC is pleased to submit this proposal for the WORK as listed below:
 CES # 2023-03-G114-ALL Job Order Contracting(JOC)- Fencing- Landscaping

BASE BID- \$354,740.95
 Remove and Dispose Existing 4' CL Fence, West Side, Barb Wire Fence East Side

Supply and Install Approx. 1950' x 6'H Ameristar Montage Plus Genesis Fence W/Quad Flair and Double Rings
 Supply and Install 2 1/2" Post Set in Concrete
 Supply and Install 1- Set DD Montage Plus Genesis 3 Rail Swing Gate, Approx. 16'W x 6'H
 Supply and Install 4" Gate Post Set in Concrete
 Supply and Install Ameristar Strong Arm / Hinge Kit
 Supply 4- Additional 6'H Ameristar Montage Plus Genesis Panels

ALT. ADD- \$198,908.92
 Supply and Install Approx. 1300' x 6'H Ameristar Montage Plus Genesis Fence W/Quad Flair and Double Rings
 Supply and Install 2 1/2" Post Set in Concrete

Cost Includes CES Pricing
 Cost Includes Tax and 2.0% Bond

Exclusions: Permits, Grading, Staking, Clearing Fenceline, Private Line Spots
 Concrete/Blacktop Coring, Cutting and Patching, Fence Removal

SPECIAL PROVISIONS: Excludes Scale Wages

TOTAL PRE-TAX COST: SEE ABOVE TERMS: _____
 6.6875% TAX: SEE ABOVE
 2.0% Bond: SEE ABOVE
 TOTAL WITH TAX: SEE ABOVE

(Sales tax will be added unless proper documentation stating exempt status is provided) (To be determined by Credit Manager)

Price is valid for 30 days

By signature below, the customer acknowledges that he/she is duly authorized to sign this agreement, has read and accepts the Contract terms and conditions set forth on page 2 and inclusive of any attachments.

TRIWEST FENCE LLC

By: Chris Sibole
 Title: Chris Sibole/ Estimator / Project Manager
 Print Name and Title

Accepted By: _____
 (Company Name)

By: _____
 Title: _____
 Print Name and Title

TERMS AND CONDITIONS

- 1 **General Terms.** TriWest Fence LLC or its subsidiary ("CONTRACTOR") agrees to provide the labor and materials (collectively the "WORK") specified on the proposal set forth on the reverse side hereof (the "front page") within a reasonable time. BUYER agrees to pay the amount shown in current U.S. funds upon substantial completion of the work per the payment terms on the reverse side hereof.
- 2 **Installation of Fence.** Unless otherwise agreed to in writing, BUYER shall fully cooperate in allowing CONTRACTOR'S installation of the fence by doing each of the following: (a) clearing a sufficient working area of all obstructions and removable hazards; (b) surveying, grading, locating and staking the fence line and by verifying all property lines and identifying all utility lines; (c) notifying CONTRACTOR'S crew of all potential work area hazards; (d) coordinating CONTRACTOR'S work with the activities of all other persons at the job site, including others contractors, crews, supervisors, architects and owners; and (e) obtaining all appropriate building permits or other form of governmental permission. The estimated completion date shall be extended for as long as BUYER fails to comply with this provision, and for all delays reasonably beyond CONTRACTOR'S control. BUYER shall be deemed to have accepted the goods and work performed upon payment in full.
- 3 **Payment, Default and Remedies.** If BUYER does not make payment in full upon substantial completion, CONTRACTOR may pursue any and all collection activity it deems necessary to collect on BUYER'S obligation. BUYER shall be responsible for all costs of collection, including but not limited to, all collection agency charges, court costs, attorneys' fees and lien fees, and all costs and attorneys' fees incurred in collecting upon any judgment. Interest will accrue on all unpaid balances, lien expenses, collection expenses and attorneys' fees from the date incurred at the rate of twenty-one percent (21%) per year or at the highest rate allowed by applicable law. CONTRACTOR may apply all payment or portions thereof to any outstanding attorney fees, court costs, collection expenses, interest and principal as CONTRACTOR, in its sole discretion, deems appropriate. This Agreement shall be construed in accordance with the laws of the State and County in which the project is located.
- 4 **Changes and BUYER'S Cancellation.** If BUYER requests any change in the type, quality or quantity of the fencing to be provided by CONTRACTOR hereunder, BUYER shall pay, in addition to the purchase price shown on the front page, CONTRACTOR'S standard charge for all additional fence and for such additional labor material and travel expenses as are incurred by CONTRACTOR in connection with such change. If, prior to CONTRACTOR'S delivery of the fencing, BUYER cancels such delivery of the fencing, BUYER shall be obligated to pay CONTRACTOR, as liquidated damages and a restocking fee, but not as a penalty, the amount equal to twenty-five percent (25%) of the CONTRACTOR'S standard charge for all special order materials. After CONTRACTOR has begun delivery of the fence, but before installation has begun, BUYER may cancel this Agreement by paying CONTRACTOR, as liquidated damages and as a restocking and transportation fee, but not as a penalty, the amount equal to fifty percent (50%) of the purchase price shown on the front page.
- 5 **Cumulative Remedies.** To the greatest extent permitted by applicable law, BUYER'S obligation hereunder and all of CONTRACTOR'S rights and remedies provided by herein and/or by applicable law, are cumulative, and CONTRACTOR shall be entitled to exercise any and all rights and remedies. BUYER acknowledges that its obligation to pay CONTRACTOR is an independent covenant, and BUYER acknowledges that it shall have no offset rights and may not withhold payment of any monies owing to CONTRACTOR hereunder. Nothing herein, however, shall be construed to release CONTRACTOR from any obligation which it may owe to BUYER.
- 6 **Lien Rights.** BUYER acknowledges that CONTRACTOR has and may exercise all lien rights against the property upon which the work is performed. To the greatest extent permitted by law, BUYER and/or OWNER hereby waive any and all objections to any defects in any such lien documents. Contractor's exercise or non-exercise of such lien rights will not alter or amend this Agreement or release any of Buyer's obligations hereunder.
- 7 **Amendments; Waivers; Entire Agreement.** Except by a specific written document executed by the parties hereto, none of the terms, covenants, representations, warranties or conditions hereof may be waived, amended, modified, superseded or canceled. Forbearance or delay shall not be deemed a waiver. A single or partial exercise of any right or remedy shall not preclude further exercise thereof or of any other right or remedy. Any written waiver shall be strictly construed and shall not be extendable. This Agreement contains the parties' entire understanding and supersedes and replaces all prior and contemporaneous agreements and understandings, oral written or implied. All documents and instruments created hereafter and concerning this transaction, including any one or more work orders or purchase orders, shall not prevail over the terms of this Agreement.
- 8 **Limited Warranty.** All goods, supplied are warranted to be fit for the intended purposes for which such goods are used for a period of one (1) year. THERE ARE NO WARRANTIES WHICH EXTEND BEYOND THE DESCRIPTION OF THE GOODS AND WORK TO BE PERFORMED AS CONTAINED ON THE FRONT PAGE. BUYER shall have no claim for incidental, consequential, special or proximate damages.
- 9 **Indemnity.** To the greatest extent permitted by law, BUYER shall indemnify, defend, hold and save CONTRACTOR (and its officers, shareholders, directors, agents, employees, servants and independent contractors) harmless from all claims and expenses, including court costs and attorneys' fees, for damages or injuries to persons or property which are related in any manner, directly or indirectly to this Agreement or to the fence (including its location) regardless of whether the injury or damage is caused in part by CONTRACTOR'S negligence or any other act or omission of CONTRACTOR or its agents, provided however, that BUYER shall not be obligated to indemnify CONTRACTOR for his sole negligence or willful misconduct.
- 10 **Successors and Assigns.** This Agreement shall be binding upon and shall inure to the benefit of the heirs, personal representatives, successors and assigns of the parties hereto.
- 11 **Severability.** If any provision of this Agreement is held unenforceable, CONTRACTOR may sever from this Agreement the language which makes such provision unenforceable and this Agreement shall be construed as if it did not contain the language and the rights and obligations of the parties shall be enforced accordingly. Alternatively, CONTRACTOR, at its sole option, may cancel this entire Agreement.
- 12 **Headings.** All paragraph headings and other headings set forth in this Agreement are for reference only and shall not be considered in interpreting the intent of the parties with respect to the matters set forth in this Agreement.
- 13 **Representations and Warranties.** Despite any agency capacity, the person signing this Agreement, personally and on behalf of BUYER, warrants and affirms to CONTRACTOR that the person signing this Agreement for any entity has full authority to do so and to thereby bind such entity.
- 14 **BUYER MUST HAVE A CURRENT CREDIT APPLICATION ON FILE WITH CONTRACTOR.** All credit and financial information provided by BUYER to Contractor is true, accurate and complete, contains no material omissions, and may be reasonably relied upon by CONTRACTOR.

CITY OF HOBBS REQUISITION/QUOTE FORM
(Purchases \$500.00-\$5,000.00 SPD & GSA Contract)

TO: CPO

VENDOR NAME:
ADDRESS:

1) Cooperative
Educational Services
PO Box 81045
Albuquerque, NM
87198

2)

3)

FROM: POSD

DATE: 2-23-2023

PHONE/FAX NO:

QTY	DESCRIPTION ITEM(S) SERVICE TO BE PURCHASED	UNIT PRICE	TOTAL PRICE	UNIT PRICE	TOTAL PRICE	UNIT PRICE	TOTAL PRICE
1	Prairie Haven Cemetery Fence Project		253,666.80				
TOTAL AMOUNT			\$253,666.80				
DELIVERY DATE							
ESTIMATED SHIPPING CHARGES							

CHECK ONE: STATE CONTRACT / GSA CONTRACT CONTRACT NO. 2023-03-G1110-ALL EXPIRATION DATE _____

SPD or GSA contracts should be attached or on file in CPO. GSA contracts must have a letter from the contractor indicating a willingness to extend pricing, and all terms to the City of Hobbs.

AWARD TO: Guadalupe Mountain Fence c/o CES POINT OF CONTACT: Clint (If new vendor make sure address is on this form)

If lowest price is not recommended, please state why (subject to approval by CPO) _____

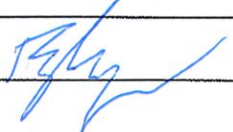
Account No. 19-4019-43011 Prepared By: Wade Whitehead Department Approval: 

WHITE-CPO PINK-Department